

THE UNIVERSITY SCIENCES BUILDING NORTHEASTERN, USA



Final Report

Chris Dunlay

Faculty Consultant: Dr. Boothby

4.4.2012

The University Sciences Building

Northeastern, USA



Chris Dunlay

Structural Option

Dr. Thomas Boothby

General Building Information

Size	209,000 SF
Function	Classroom/Office/Laboratory
Height	142' (max) 114' (min)
Construction	August 2006 - December 2009
Construction Cost	Withheld by Owner
Delivery Method	Construction Manager at Risk

Architecture

- Two building System
 - Building 1– Offices and laboratories
 - Building 2 - Classrooms, Offices, Collaborative Spaces
- Central Idea - Atriums and Open Interactive Spaces
- Unevenly spaced windows with aluminum trim and zinc paneling façade
- Complex floor plans producing interesting cantilevers

Project Team

Owner	Not Released
Architect	Mack Scogin Merrill and Elam
Structural	ARUP
MEP	ARUP
Civil	Civil and Environmental Consultants



Structure

Foundation:

- Drilled Caissons, strip and column footings

Superstructure:

- Lower floors: Formed Concrete columns, beams, and slabs
- Upper Floors: Steel columns and composite floor system
- Lateral System: Concrete shear walls and steel brace frames

Construction

- Foundation of building two was sequenced with construction of building one level 3.
- Complex floor framing and connections delayed fabricators and erectors, delaying overall schedule.

MEP Systems

Mechanical:

- 11 Air Handling Units ranging from 4,800 - 40,700 CFM
 - 5 AHU's match exhaust unit with energy recovery wheel
- Multiple zones supplied by VAV boxes with terminal reheat
- Chilled water and steam supplied by the campus utility plant
- 3 atrium smoke exhaust fans

Electrical/Lighting:

- 4.16 kW main switchboard
- Main power is 480Y/277V 3 phase, 4 wire
- 900kW diesel emergency generator
- Lighting consists of fluorescent, metal halide, and decorative LED's

Acknowledgements

Academic Acknowledgements

Penn State AE Faculty

Dr. Thomas Boothby

Industry Acknowledgements



ARUP

Mack Scogin Merrill Elam Architects

Special Thanks

PJ Dick Project Team

Matt Wetzel

Bill Hawk

Table of Contents

Executive Summary	6
Building Introduction	7
Structural Overview	8
Foundations.....	8
Floor Systems	8
Framing System	9
Lateral System	10
Roof System	10
Design Codes	11
Materials Used	11
Gravity Loads.....	12
Dead and Live Loads.....	12
Building Weight	12
Snow Loads.....	14
Lateral Loads	16
Wind Loads.....	16
.....	20
Seismic Loads	21
.....	22
Lateral Load Distribution.....	23
Problem Statement	25
Problem Solution.....	26
Structural Depth Study.....	27
Design Goals -	27
Methodology –	27
Materials –	28
Code and Specification Compliance –	28
Design Load Combinations –	28
Gravity System –	29
Gravity Loads.....	29
Self-Weights	29
Design Process.....	30
Two Way Flat Plate Design	31

spSlab Analysis –	31
RAM Concept Analysis –	32
Edge Beam Design	35
Concrete Truss Design-.....	36
Lateral System	41
Design Goals	41
Methodology	41
Lateral Loads – Wind	41
Lateral Loads – Earthquake	45
ETABS Analysis.....	47
Earthquake Analysis	48
Model	49
Relative Stiffness	50
Shear Wall Design	54
Moment Frame Column Design	57
Moment Frame Beam Design	58
Mechanical Breadth Study	61
Construction Management Breadth	64
Cost Analysis.....	64
Schedule Impact.....	65
Conclusions	67
References.....	68
Appendix A: Gravity Calculations	69
Appendix B: Truss Design	79
Appendix C: Shear Wall Design	102
Appendix D: Concrete Moment Frame Design	112
Appendix E: Detailed Schedule and Cost	121
Appendix F: Lateral Calculations	128
Appendix G Tycal Plans	135

Executive Summary

The University Sciences Building (USB) is a new and modern 209,000 SF educational facility located on an urban campus in the Northeast, USA. The USB has many interesting architectural and structural features that make it one of the most unique buildings in the area. Such features include the use of multi-story atriums, one-of-a-kind cantilevers, and a black zinc paneling façade. The showcase atrium is a 3 story, 4400 sq. ft. atrium that utilizes a helical ramp as its main egress to 3 levels, with 2 classrooms that are located through its core. The facility consists of two different buildings, Building 2 – North and Building 1 – South that are connected by a 4 story passage. For the purpose of this report and those previous, only Building 1 will be considered analysis and the redesign

The existing structural system consists of a concrete foundation, steel superstructure with a dual shear wall/braced frame lateral system. The lateral system in Building 1 includes 8 braced frames and 3 shear walls, of which both lateral systems run the full height of the building. The gravity system is composite deck on steel framing with concrete topping.

Upon the analysis of Technical Reports 1 and 3, it was found that the existing building performs adequately under gravity and lateral loads when considering strength and serviceability. Although due to the complexity of the superstructure construction with steel, the construction schedule and cost were longer and larger than their original estimated amounts. For this reason, a redesign of a full concrete system will be investigated. Since the bottom three levels, storage and a parking garage, were originally concrete, only levels 4-Roof will be considered for the redesign. A two way flat plate floor system will be designed as the gravity system and shear walls with concrete moment frames interactive system will be analyzed as the lateral system.

The two way flat plate floor system uses a 12" thick slab with a compressive strength ($f'c$) of 6,000 psi. Gravity columns sizes range from 24"x24" to 12"x12" and moment frame columns are 24"x18"; both with an $f'c$ of 6000 psi. Due to the complexity of the column/slab configuration, typical bays do not occur regularly. Bay sizes range from 27'x30' to 16'x16'.

The lateral system consists for 3 shear walls resisting forces in the North-South direction, 4 in the East-West direction, 4 concrete moment frames in the North South Direction, and 3 concrete moment frames in the East-West direction. Shear walls run the height of the building and the moment frames vary in layout. Due to the added weight of concrete, seismic loading controls for both strength and deflection.

Since the driving factor of changing the superstructure from steel to concrete was the complexity and confusion of erection and detailing the steel, a construction management study will be investigated to compare schedules and costs.

Finally, a mechanical breddy study will be investigated with an alternative glazing material and how it can potentially lower the cooling load on south facing spaces.

Building Introduction

The University Sciences Building is a pioneering sciences facility pushing the envelope on innovative research and education. The 209,000 square foot dual building is strategically nested on a 5.6 acre site on the urban university in Northeastern, USA. The building includes 300+ offices, state-of-the-art laboratories, classrooms, lecture halls, a 250 seat auditorium, and a 147 space parking garage. The University's standard building aesthetics include a symmetrical layout and typically a beige brick veneer. The USB's extravagant cantilevers and complex building enclosures express the University's commitment to innovative architecture and sustainability.

The building was designed around the common idea of atrium space and other open spaces exposed to light, predominately through curtain wall systems. The intent was to let these open areas serve as collaborative spaces for interaction among students, researchers, and professors. The featured atrium of the building is its 3 story helical structure, which serves as a ramp to levels 3–5 with classrooms intermediately located through its core (Figure 2).

The sophisticated and 'edgy' design of the façade expresses the University's movement to push the envelope for not only the sciences but also its architecture. The material used to clad the building is a unique zinc material. Both the black zinc molded squares and the sliver aluminum window trim give the building a different and uneven appearance which sparks interest towards the building

Each floor's different floor plans presents one of a kind overhangs and cantilevers which really express the structure of the building (Figure 3). The placement of key structural components are carefully placed to preserve optimal structural function from floor to floor.



Figure 1 – Google Maps aerial view of site



Figure 2 – Helical ramp



Figure 3 – South Cantilever

Structural Overview

The University Sciences Building sits upon a Site Class C (Geotechnical Report verified with ASCE 7-05 Chapter 11) with drilled 30" caissons, caisson caps, spread, continuous, stepped footings, grade beams and column footings. Levels 1-3 use concrete beams and slabs with a combination of concrete columns and steel encased columns. The upper floors of both buildings use a composite beam/slab system and continue with steel and encased columns. The lateral systems consists of shear walls and braced steel frames. The shear and retaining walls start from the grade and end at various heights around the building. The braced frames are composed of wide flange columns with HSS diagonals that also reach various heights.

Foundations

The design and analysis of foundations are in accordance with the geotechnical report provided by Construction Engineering Consultants, Inc and ASCE 7-05. Schematic and design development stages were conducted with a safe assumption that the soil class was solid rock. The majority of the University's soil has been geologically tested to show this. As time proceeded and the geotechnical report was released, it was found that the site class was different than anticipated and a site class C was determined appropriate. This induced a complete redesign of Building 2's foundation along with using a new 'flowable fill' for backfill for Building 1. Flowable fill is entrained with fly ash, cement, and other agents to generate negligible lateral pressure on surrounding foundation walls but maintains a compressive strength of 500 psi.

It has been concluded from the structural drawings that the allowable soil/rock bearing pressures for spread footings on weathered shale are 6000 psf. Likewise for siltstone/sandstone allowable pressures are 12000 psf. In addition, caissons socketed 5' into siltstone/sandy stone are to have an allowable pressure of 50 ksf.

The building load path starts from the floor systems and is distributed to columns and then to their respective caissons or interior column footings. For exterior perimeter caissons, they are connected with grade beams to interior caissons or grade column foundations. The slab on grade (SOG) is to be poured onto compacted soil to withstand 500 psf and a minimum of 6" of compacted Penn DOT 2A or 2B material. Furthermore, the fill must be compacted to 95% of the dry density per ASTM D 1557. A vapor barrier is then required to be placed between the fill and the slab.

Expansion joints should be used between the footings and floor slabs to minimize differential settlement stresses. The slab on grade is designed to have an f'_c of 4500 psi of normal weight concrete and a mix class C.

Floor Systems

Due to the complexity of the floor layouts, typical bays occur irregularly and are comprised of a variety of beam sizes and lengths (Refer to appendix E for floor plans). In Building 1, floors 1 - 3 utilize concrete reinforced beams that range in size from 50"x24" to 10"x12", integral with formed 6" reinforced slabs. The upper floors utilize composite and non-composite beam construction. These floor systems range from 1" x 20 gauge metal deck with 5" reinforced concrete topping to 2" x 18 gauge metal deck with 4.5" reinforced

Final Report – 4.4.2012

concrete topping. The most recurring slab is a composite 2"x18 GA deck with 4.5" normal weight concrete topping, which is found in both building 1 and 2 on floor 4-roof. Areas on levels 4 and 5 of Building 1 brace the metal decking between beams and girders with L4x4x3/8".

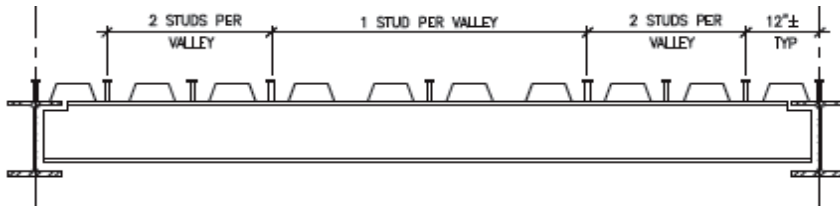

Figure 4. Perpendicular Decking Section – Case 3

The composite and non-composite decks are placed with the ribs of the deck perpendicular to the infill beams to maintain the rigidity of the system. This proved to be a conflict to construct with the placement of shear studs. Where it is efficient to place studs along the length of the beam uniformly normal to the valley and peaks of the deck, it was extremely difficult to maintain this layout with the odd angling placement of particular beams (Figure 4).

Framing System

The USB has three different types of columns; reinforced concrete, encased A992 steel with concrete, and A992 wide flange steel. Reinforced concrete columns vary in size from 24" to 18" diameter circular columns and 16"x18" to 33"x37" rectangular columns. Also, wide flange columns range from W12x40 to W21x210. Levels 1 and 2 of Building 1 have both circular and rectangular concrete columns. Level 3 of Building 1 uses circular/rectangular encased steel and circular reinforced doesn't hold true for three shear walls that start with a connection to a caisson cap at grade and rise 72' to

columns. Framing girders are then connected to these columns with simple and complex connections. (e.g. pin-pin, moment). The layout of the girders and beams have been arranged with much complexity and provide a challenge for analysis. This complexity not only produced adversity for the fabricators and erectors, increased the price of the building, but also delayed the floor to floor connection schedule. The most nearly identified typical bay has 30'x27' dimensions. .

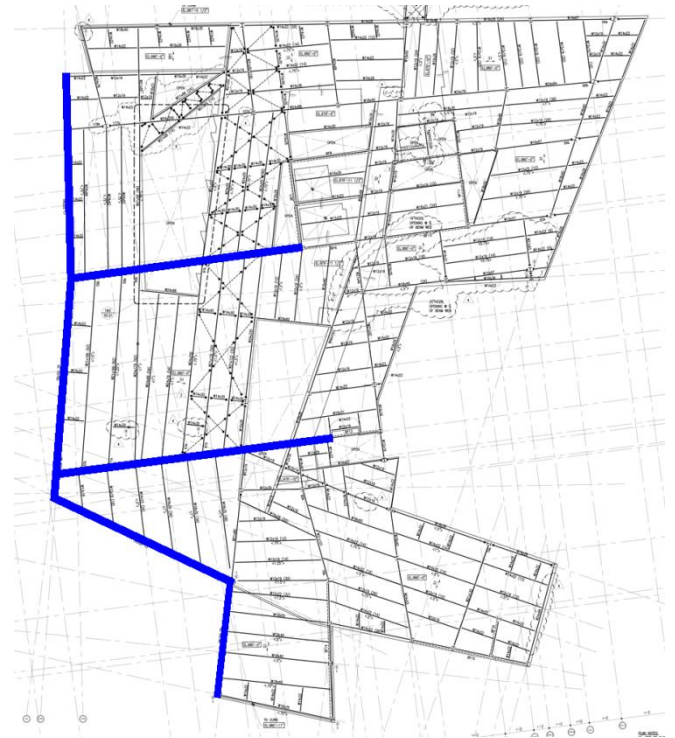

Figure 5- Highlighted truss elements from Building 1 Level 8.

An intricate and vital part of this structural framing system is the truss system in Building 1 which varies in height from Level 6 to the Roof (Figure 5). These trusses are comprised of chord sizes as big as W30x292 and intermediate bracing elements as small as W14x53. Due to the complex cantilevers and floor plans, a system

Final Report – 4.4.2012

needed to be implemented to handle the buildings loads. This system is well hidden in the building and parts where it can be seen (through some windows) presents an interesting look for the building.

Lateral System

The most common lateral force resisting system in The USB is braced frames. The USB utilizes 16 different braced frames between the two buildings. The majority of these are framed within a single bay. Others are 'Chevron' braced frames between two bays and a few span through 3 or more bays.

In Building 1 these braced frames are connected to shear walls where the load is taken from steel elements to concrete elements. These concrete elements are generated from the formed concrete walls lining the 147 parking spot garage. This adds a considerable weight to the building. All shear/retaining walls employed in building are kept on the lower floors, which has been assumed to level 6. Refer to Figure 6 for the layout of brace frames (red) and shear walls (green) on Level 6. The challenge for Technical Report 3 will be to figure out how these lateral force resisting systems receive force on all floors of the building.



Figure 6 – Level 6 plan showing shear wall/braced frame layout

Roof System

This dual building system has 5 different roof heights which take into account mechanical penthouses. Figure 7

gives a description of these varying heights in reference to grade elevation of 0'-0" (+880'). The framing of the roof is composed of wide flange framing with a 3" x 18 GA metal roof deck. The construction of the roof includes a modified bituminous roof system. This system ranges in size from 3" to 12". This system is to undergo a flood test with 2" of ponding water for 24 hours to test for adequacy.

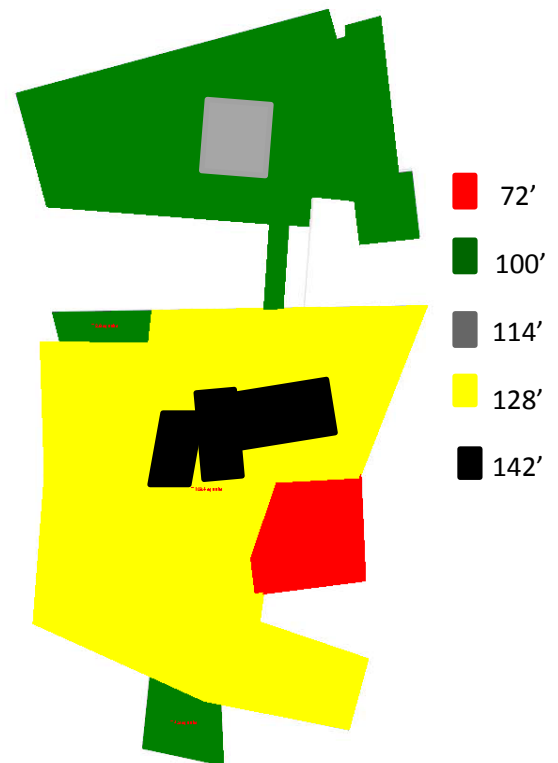

Figure 7 - Plan showing varying roof elevations

Design Codes

In accordance with the specifications of structural drawing S0.01 the original design is to comply with the following codes:

- 2006 International Building Code with local amendments (IBC 2006)
- 2006 International Fire Code with local amendments (IFC 2006)
- Minimum Design Loads for Building and other structures (ASCE 7-05)
- Building Code Requirements for Structural Concrete (ACI 318)
- AISC Manual of Steel Construction LRFD 3rd Edition

These codes were also used in hand calculations and verifications in this Technical Report and those forthcoming.

Materials Used

The materials used for the construction of The USB are described in the following tables including relevant specifications:

Structural Steel			
Type	ASTM Standard	Grade	Fy (ksi)
Wide Flange	A992	50	50
Channels	A572	50	50
Rectangular and Round HSS	A500	B	46
Pipes	A53	E	35
Angles	A572	50	50
Plates	A572	50	50
Tees	A992	50	50

Concrete			
Location in the Structure	f'c	Weight	Mix Class
Footings, Caissons, Grade Beams	4000	Normal	A
Slab On Grade	4500	Normal	C
Walls and Columns	4500	Normal	C
Beams and Slabs	4500	Normal	C
Slab on Metal Deck	4000	Normal	C
Equipment Pads and Curbs	4000	Normal	B
Lean Concrete	3000	Normal	E

- f'c is the concrete compressive strength at 28 days or at 7 days for high early strength concrete.
- Mix class as defined by project specifications

Aggregate	
Type	ASTM Standard
Normal Weight	C33
Light Weight	C330 and C157

Table 1 - Summary of Materials used on The USB Project with applicable specifications

Gravity Loads

Per the requirements of Technical Report 1, dead, live, and snow loads are to be calculated and verified to those provided on the structural drawings. Alongside these calculations and verifications spot check calculations of gravity members for adequacy are also provided. These calculations can be found in appendix A.

Dead and Live Loads

The structural drawings provide a schedule of superimposed dead and live loads for particular areas (Figure 9). Calculations of certain loads verify those provided in the table and in some cases are found to be conservative. This was perhaps a consideration due the complexity of the floor layout. Self-weights were also calculated to be applied in addition to the given dead and live loads.

Building Weight

The building weight was calculated considering superimposed dead loads, self-weights of columns, shear walls, braced frames, roofs, and exterior wall loads. This section is intended to provide weights for seismic calculations to generate total base shear. This value is then compared to the value provided on the drawings (See Seismic Section). Without the assistance of computer software to generate accurate weights, overall assumptions had to be made. First, from the provided schedules, pounds per square foot of reinforced concrete beams were tabulated considering weight of normal weight concrete (145 pcf) and supplemental reinforcement bars. Secondly, formed slab and metal deck slab pounds per square foot were calculated. Next linear takeoffs of steel beams were tabulated on floors 3-6 of building 1. This process reoccurred for floors 5-6 in building 2. Also counts of columns from the column schedule were made. A weight per lineal foot was noted per column. Next, the building enclosure is broken up into two groups; curtain walls and stud build out system. From assembly weight estimates it was assumed 15 psf for the curtain wall and 30 psf for the stud build out. Finally, the provided superimposed dead loads was summated and yielded a total pound per square foot for the floor. With all of the slabs, concrete beams, steel beams, columns, façade, and superimposed dead loads calculated to either a pound per square foot or linear foot, they are ready to be multiplied by its respective dimensions to result a total kilo pound per floor.

With a weight of kips per floor, it was then divided by that floor's square footage resulting in a kip per square foot (ksf) for that floor. As stated before, level 3-6 in building 1 and levels 5-6 in building 2 were calculated with detailed member calculation. After investigation and grouping of these numbers per their typical floor layout, an average ksf was calculated to be applied to similar levels. This ksf was then applied to the remaining floors

Final Report – 4.4.2012

square footage once again resulting in kips per floor. The individual kips per floor were then summed to yield a total building weight. The following tables show numerical calculation. It is important to note that Technical Report 3 with provide a more detailed calculation of the building weight.

Provided Superimposed Dead Loads and Live Loads		
Locations	Superimposed Dead Load (psf)	Live Loads (psf)
Garage	35	50
Planetary Robotics	15	150
Loading Dock	5	250
Storage	35	125
Classroom	35	40
Halls, Assembly, Public Areas	35	80
Office, Meetings Rooms	35	50
Mechanical and Machine Room	75	100
Roof	35	30
Green Roof 1	35	30
Garage Roof	200	100
Green Roof 2	200	30
Mechanical Roof	35	50
Bridge 1	75	100
Roof Pavers	50	100
Roof River Rocks	55	30

Table 2 - Table of provided superimposed dead loads and live loads

Building 1			
Level	~ Square Footage	Weight (K)	KSF
3	33,676	5,180.689	0.153839
4	20,983	2,644.86	0.126048
5	22,359	3,190.55	0.142697
6	27,633	3795.15	0.137342
7	21,018	2,592.60	0.123352
8	25,697	3,455.30	0.134463
9	21,970	2,954.15	0.134463
Total	173,336	23,813.32	0.137382

Table 3 - Table of floor approximate square footage, weights (K), and KSF.

* Note: Level 5 of Building 2 was calculated with member weight accuracy and its respective KSF was used as an average for the remaining floors.

From the structural loading diagrams, Live Loads were noted and compared to those provided in ASCE 7-05. Most of these values were verified by the code and others were found to be very conservative. A summary of these results can be found in Figure 11.

Live Loads			
Location	Design Live Load (psf)	ASCE 7-05 Live Load (psf)	Notes
Garage	50	40	May be from storage during construction
Planetary Robotics	150	200	N/A
Loading Dock	250	N/A	N/A
Storage	125	125	Anticipated light storage
Classroom	40	40	N/A
Halls, Assembly, Public Areas	80	80	N/A
Office, Meetings Rooms	50 (+20)	50 (+20)	+20 for Partition load
Mechanical and Machine Room	100	100	N/A
Roof	30	20	N/A
Green Roof 1	100	100	N/A
Garage Roof	30	30	N/A
Green Roof 2	50	60	Project green roof specifications may cause discrepancy
Mechanical Roof	100	N/A	N/A
Bridge	100	100	Serves as a corridor
Roof Pavers	100	100	N/A
Roof River Rocks	30	N/A	N/A

Table 4 - Comparison table of live loads from design documents and ASCE 7-05

Snow Loads

Snow loads were calculated in accordance with Chapter 7 of ASCE 7-05. This section highlights design criteria for The USB's location and design procedures. All design criteria and loads are summarized in Figure 12.

Flat Roof Snow Load Criteria			
Variable	Design Value	ASCE 7-05	Notes
Ground Snow Load, p_g (psf)	30	25	Fig -1 Conservative approach
Snow Exposure Factor, C_e	1.0	1.0	Table 7-2.
Snow Load Importance Factor, I_s	1.1	1.1	Table 7-4, Category III
Thermal Factor, C_t	1.0	1.0	Table 7-3, All other structures
Flat Roof Snow Load, p_f (psf)	27	23.1 ($=0.7C_eI_s p_g$)	Eq 7-1, Conservative Approach
Snow Specific Gravity γ_s (pcf)	N/A	18	Eq 7-3
Base Snow Accumulation Height, h_b	N/A	1.3	N/A

Table 5 - Comparison table of snow load criteria from design documents and ASCE 7-05

The structural drawings provide design criterion that is accurate, but conservative in two locations. Figure 7-1 from ASCE 7-05 clearly shows that the building location should be designed with a 25 psf ground snow load. This difference is only slightly conservative. Likewise, the flat roof load calculation, with using a pg of 30 psf, should yield 23.1 psf and not 27 psf. Once again this is a conservative approach but throughout this technical report and those forthcoming, a pf of 23.1 psf will be used. Snow drift calculations were also performed for 15 potential locations on 5 different roof heights. Figure 13 shows snow drift calculations, along with Figure 14 and 15 providing a plan and elevation to assist drift calculations.

Snow Drift Calculations											
Location	General			Windward				Leeward			
	hr	hc	hc/hb	Lu (ft)	hd (ft)	wd (ft)	pd (psf)	Lu (ft)	hd (ft)	wd (ft)	pd (psf)
1	14	12.71	9.85	25	1.25	4.99	22.3	28.5	1.35	5.41	24.2
2	14	12.71	9.85	26.75	1.30	5.20	23.3	25	1.25	4.99	22.3
3	14	12.71	9.85		VOID				VOID		
4	14	12.71	9.85	68	2.19	8.74	39.1	25	1.25	4.99	22.3
5	14	12.71	9.85	25	1.25	4.99	22.3	39.5	1.64	6.55	29.3
6	14	12.71	9.85	25	1.25	4.99	22.3	25	1.25	4.99	22.3
7	14	12.71	9.85	25	1.25	4.99	22.3	54.75	1.95	7.82	35.0
8	56	54.71	42.39	35.25	1.53	6.14	27.5	41	1.67	6.69	29.9
9	56	54.71	42.39	37	1.58	6.31	28.2	70	2.22	8.87	39.7
10	28	26.71	20.70	25	1.25	4.99	22.3	35.25	1.53	6.14	27.5
11	28	26.71	20.70	25	1.25	4.99	22.3	99.5	2.63	10.53	47.1
12	14	12.71	9.85	25	1.25	4.99	22.3	25	1.25	4.99	22.3
13	14	12.71	9.85	43.75	1.73	6.93	31.0	25	1.25	4.99	22.3
14	14	12.71	9.85	25	1.25	4.99	22.3	25	1.25	4.99	22.3
15	14	12.71	9.85	58.5	2.02	8.09	36.2	25	1.25	4.99	22.3

Table 6 - Table of Snow Drift Calculations. Note: Snow Drift Loads are in addition to flat roof snow load. Total Snow @ max drift location = 23.1 psf + 47.1 psf = 70.2 psf



Figure 9 - Elevation looking NE detailing roof elevations

Lateral Loads

As part of technical report 1, wind and seismic loads were calculated to retain a better understanding of the lateral systems to be further elaborated in Technical report 3. Without the assistance of modeling the whole structure in a structural software, it is uncertain to evaluate how much force is being distributed among the different lateral resisting elements. Assumptions were made to provide a simplified basis for calculations.

Wind Loads

Wind load calculations were conducted in accordance with Method 2-Main Wind Force Resisting System (MWRFS) procedure from Chapter 6 of ASCE 7-05. Once again, due to the complexity of floor plans and elevations which produce an undulating façade, assumptions have been made in order to perform basic calculations. Building 1 was simplified by taking the most extreme dimensions (length, base, and height) and using them to generate a box building. This allowed wind to be analyzed on a planar surface normal to the wind in both the North-South and East-West directions of Building 1. This initially would trigger the belief of a conservative approach but further investigation in Technical Report 3 may show otherwise. It is to be noted that for N-S wind, the south wind will be conservative for its elevation changes. Similarly, E-W wind has a gradual change in grade but these calculations have implemented the conservative approach.

The wind follows are particular load path which essentially drives the design of the lateral systems. The wind encounters the components and cladding of the façade which are then taken by the floor slabs. Next, the slabs carry the load to the shear walls and brace frames which deliver the load to the foundation of the building. The following tables (Figures 18-23) show resulting wind pressures and forces in both the North-South and East-West directions of Building 1.

Wind Pressures - N-S Direction							
Type	Floor	Height	Wind Pressure (psf)	Internal Pressure		Net Pressure	
				(+)	(-)	(+)	(-)
Windward	1	0	7.80	3.74	-3.74	11.54	4.06
	2	10	7.80	3.74	-3.74	11.54	4.06
	3	25	9.03	3.74	-3.74	12.77	5.29
	4	44	10.68	3.74	-3.74	14.42	6.94
	5	58	11.52	3.74	-3.74	15.26	7.78
	6	72	12.07	3.74	-3.74	15.81	8.33
	7	86	12.97	3.74	-3.74	16.71	9.23
	8	100	13.55	3.74	-3.74	17.29	9.81
	9	114	14.03	3.74	-3.74	17.77	10.29
	10	128	14.51	3.74	-3.74	18.25	10.77
	11	142	14.97	3.74	-3.74	18.71	11.23
Leeward	All Floors		-8.83	3.74	-3.74	-5.09	-12.57
Side Walls	All Floors		-13.10	3.74	-3.74	-9.36	-16.84
Roof		0-57	-16.84	3.74	-3.74	-13.10	-20.58
		57-144	-16.84	3.74	-3.74	-13.10	-20.58
		144-228	-9.36	3.74	-3.74	-5.62	-13.10
		>228	-5.61	3.74	-3.74	-1.87	-9.35

Table 7: Tabulations of North-South Wind Pressures on Building 1

Wind Forces N-S Direction							
Level	Elevation (ft)	Floor Height(ft)	Base (ft)	Wind Pressure (psf)	Resultant Force (k)	Story Shear (k)	Overturning Moment (ft-k)
1	0	0	200	7.80	7.8	321.6	0.00
2	10	10	200	7.80	15.6	313.8	156.02
3	25	15	200	9.03	25.3	298.2	631.26
4	44	19	200	10.68	37.4	272.9	1,647.57
5	58	14	200	11.52	31.1	235.5	1,802.52
6	72	14	200	12.07	33.0	204.4	2,378.33
7	86	14	200	12.97	35.1	171.4	3,015.45
8	100	14	200	13.55	37.1	136.3	3,713.27
9	114	14	200	14.03	38.6	99.2	4,401.31
10	128	14	200	14.51	39.9	60.6	5,113.50
11	142	14	200	14.97	20.6	20.6	2,930.26
Total Base Shear						321.6	N/A
Total Over Turing Moment						N/A	25,789.49

Table 8: Tabulations of North-South Wind Resultant Forces on Building 1

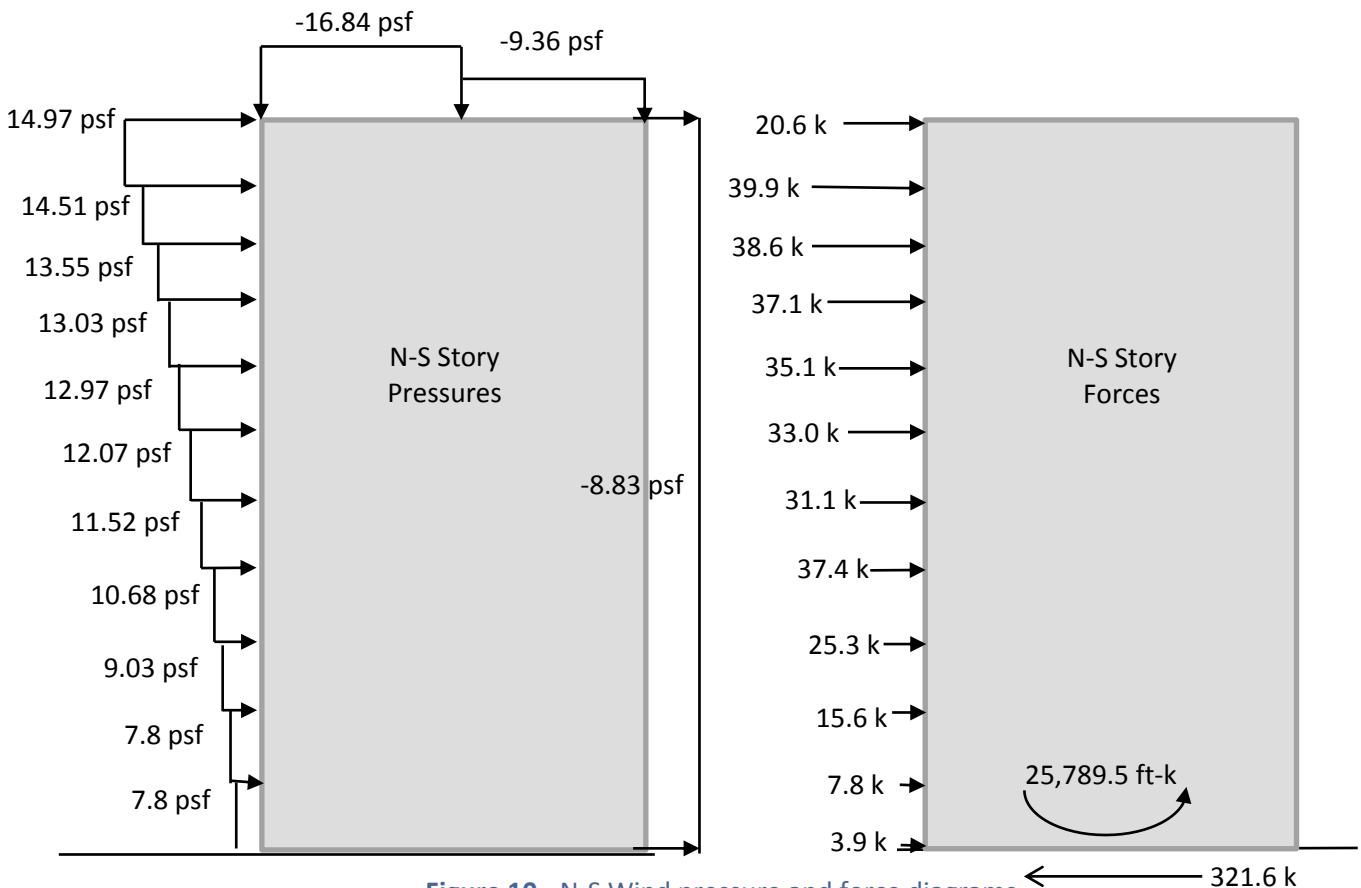

Figure 10 - N-S Wind pressure and force diagrams

Similar calculations were performed for wind in the East-West direction (Figure 20). As the elevation and grade vary on the west and east elevations, it has been assumed to simplify this by using floors 3 to 11 (penthouse roof) in the calculations. The West Elevation incorporates elaborate overhangs which will be an interesting topic of investigation in Technical Report 3. The overall assumptions of a planar elevation are intuitive at this point to be conservative but suction and lift may prove to increase the wind pressures over the initial assumptions.

Wind Pressures - E-W Direction							
Type	Floor	Height	Wind Pressure (psf)	Internal Pressure		Net Pressure	
				(+)	(-)	(+)	(-)
Windward	3	25	8.99	3.74	-3.74	12.73	5.25
	4	44	10.62	3.74	-3.74	14.36	6.88
	5	58	11.47	3.74	-3.74	15.21	7.73
	6	72	12.01	3.74	-3.74	15.75	8.27
	7	86	12.91	3.74	-3.74	16.65	9.17
	8	100	13.48	3.74	-3.74	17.22	9.74
	9	114	13.96	3.74	-3.74	17.70	10.22
	10	128	14.44	3.74	-3.74	18.18	10.70
	11	142	14.90	3.74	-3.74	18.64	11.16
Leeward	All Floors		-9.31	3.74	-3.74	-5.57	-13.05
Side Walls	All Floors		-13.04	3.74	-3.74	-9.30	-16.78
Roof		0-57	-16.76	3.74	-3.74	-13.02	-20.50
		57-144	-16.76	3.74	-3.74	-13.02	-20.50
		144-228	-9.31	3.74	-3.74	-5.57	-13.05
		>228	-5.59	3.74	-3.74	-1.85	-9.33

Table 9 - Tabulations of East-West Wind Pressures on Building 1

Wind Forces E-W Direction							
Level	Elevation (ft)	Floor Height(ft)	Base (ft)	Wind Pressure (psf)	Resultant Force (k)	Story Shear (k)	Overturing Moment (ft-k)
1	0	0	228	7.76	8.9	379.4	0.00
2	10	10	228	7.76	22.1	370.6	1,358.95
3	25	15	228	8.99	34.8	348.5	1,757.22
4	34	19	228	10.62	40.0	313.6	2,377.57
5	48	14	228	11.47	36.6	273.7	3,544.71
6	62	14	228	12.01	38.3	237.0	4,304.37
7	86	14	228	12.91	41.2	198.7	5,080.46
8	100	14	228	13.48	43.0	157.5	5,899.15
9	114	14	228	13.96	44.6	114.4	2,782.58
10	128	14	228	14.44	46.1	69.9	5,899.15
11	117	14	228	14.90	23.8	23.8	2,782.58
Total Base Shear						379.4	N/A
Total Over Turing Moment						N/A	27,105.01

Table 10: Tabulations of East-West Wind Story Forces on Building 1

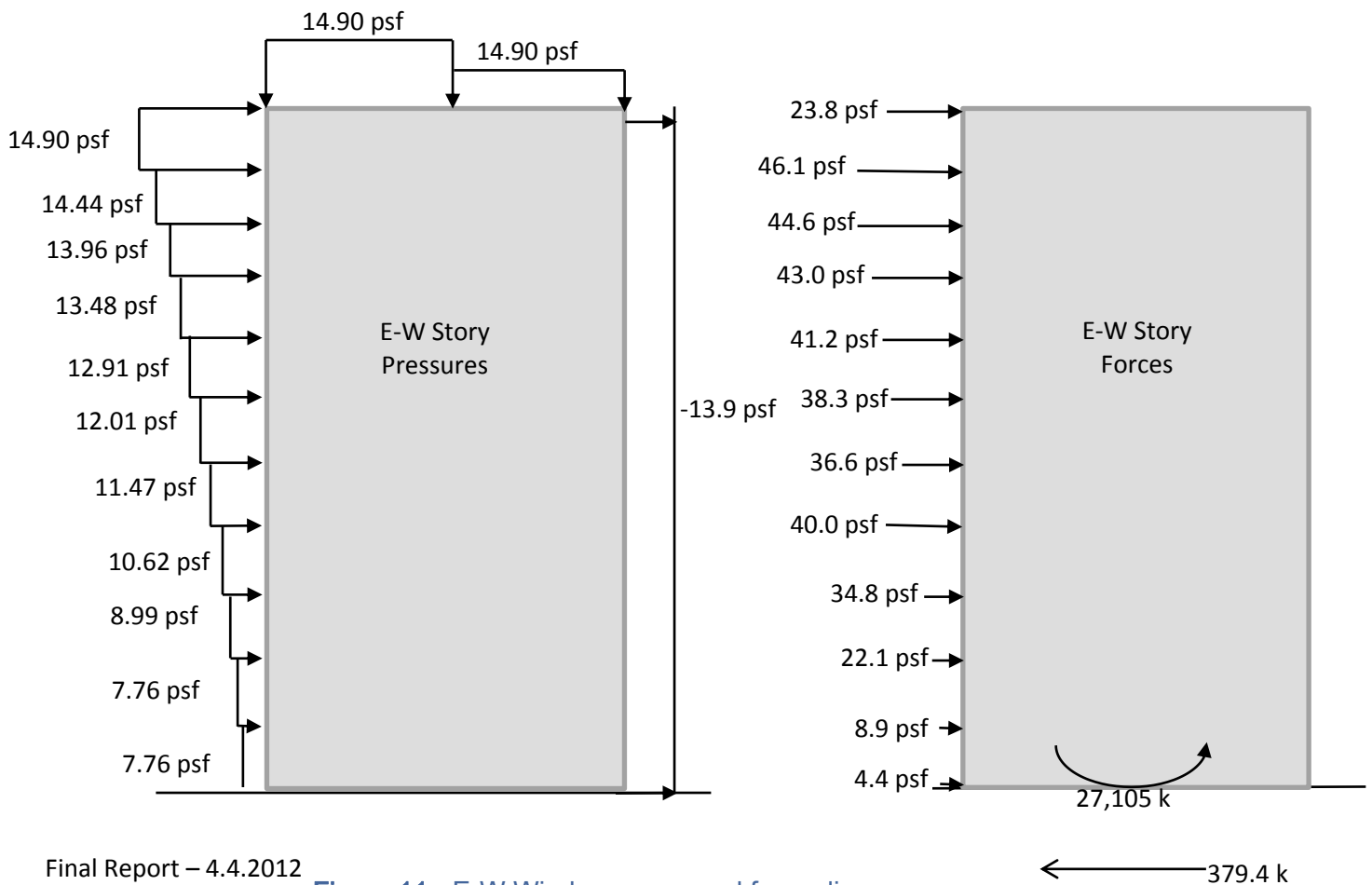

Seismic Loads

The seismic loads calculated in Technical Report 1 comply with the Equivalent Lateral Force Procedure in Chapters 11 and 12 from ASCE 7-05. Similar to the wind calculations, assumptions were made to generate proper calculations without modeling the building in structural software. Seismic loads are dependent on the building weight, which is more accurate, whereas wind assumptions are based on the dependency of the footprint and surface areas. Therefore, the seismic calculations represent a more accurate depiction of the actual structure. The structural drawings provide design criteria for this structure which can be found in Figure 23. The intent of these calculations was to compare base shears of Building 1 and Building 2 from the structural drawings with those calculated. All provided criteria was noted and found to be adequate in accordance with ASCE 7-05. The only discrepancy was the Seismic Response Coefficient, C_s . The drawings provide this value as 0.0265. Under the code, the calculated value of C_s was found to be 0.0256, which will be used to calculate the base shear in this technical report and those to follow. The approximate building period and frequency were calculated to gain an understanding of buildings characteristics.

General Seismic Information	
Site Class	C
Importance Factor (I_e)	1.25
Short Spectral Response Acceleration	0.128
1 Sec Spectral Response Acceleration	0.06
Site Coefficient (F_a)	1.2
Site Coefficient (F_v)	1.7
Response Modification Coefficient	5
Long Period (seconds)	12
Modified Short S.R.A - SMS	0.1536
Modified 1 Sec S.R.A. - SM1	0.1020
Design Short S.R.A. - SDS	0.1024
Design 1 Sec S.R.A. - SD1	0.0680
Seismic Design Category	B

Table 11 - Seismic Design Criterion

The concept of how seismic loads impact a building structure is vital to the understanding of how to employ lateral force resisting systems. The weight of the building is a direct correlation of what the building experiences during seismic activity. The weight of each floor is transferred into lateral structural elements which form into the foundations. All structural components in the ground (below grade) are assumed to be rigid with the ground itself, resulting with only the weight above grade impacting base shear (refer to the Building Weights section for representative building weights). It is to be noted that level 3 of building 1 has 50% of its floor weight below grade which means 50% of level 3's building weight was considered for the total weight of the building above grade. This is the same logic noted in Wind for the East-West direction. The following diagrams summarize the seismic calculations.

Distribution of Seismic Forces (E-W/N-S)								
Level	H (ft)	Elevation (ft)	Weight (k)	whk	Cvx	fi (k)	Vi (k)	Overtuning Moment (ft-k)
Roof	14	128	2800	2265206	0.101	59	0	7510
9	14	114	2954	2036757	0.091	53	59	6014
8	14	100	3455	1988145	0.089	51	111	5150
7	14	86	2592	1211275	0.054	31	163	2698
6	14	72	3795	1387812	0.062	36	194	2588
5	14	58	3192	866151	0.039	22	230	1301
4	14	44	2644	490034	0.022	13	253	558
3	19	25	5180	440035	0.020	11	265	285
Base	25	0	0	0	0.000	0	277	0
Total Story Forces (Base Shear, $V=C_sW$)						277	N/A	N/A
Total Overtuning Moment								18,595

Table 12 - Table of Distributed Floor Seismic Forces

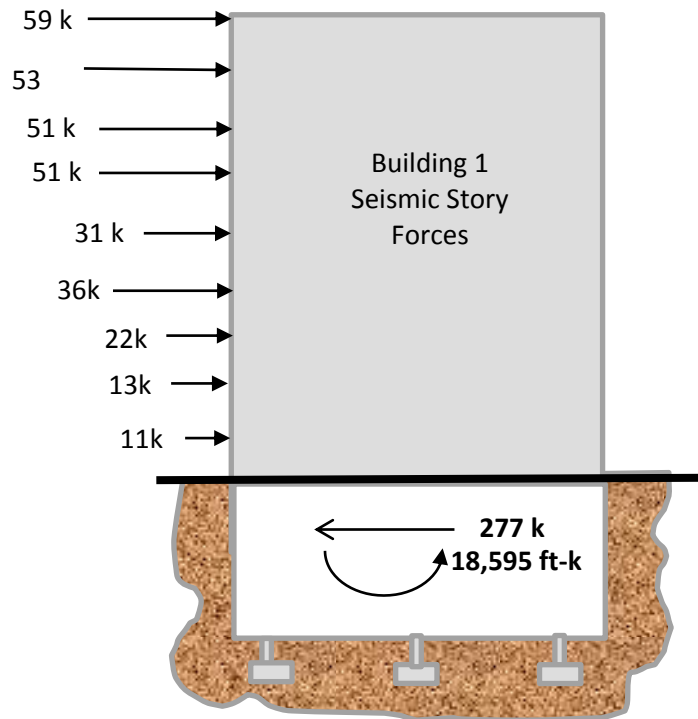

Figure 13 - Seismic Force Distribution Loading Diagram

Lateral Load Distribution

The lateral loads are resisted by the combination of the steel braced frames and shear walls. The shear walls are more commonly found in the lower levels and the braced frames rise through the height of the building. In this report, the floor diaphragms were modeled as rigid diaphragms in ETABS. The lateral loads are transferred through the façade to the floor systems and then to the lateral system. These systems will ultimately take the loads to the foundation of the building. In the interest of this providing an accurate technical report with respect to the complexity of the building, the braced frames of interest in this section are the ones highlighted below. From these frames the stiffness' are found from applying a 100 kip load at the top of each frame. After compiling that information, a ratio of each stiffness to the total stiffness is found to define a relative stiffness of each frame. This again was accomplished by applying a 100 kip load to the top of each frame. ETABS generated the following relative stiffness's (Figure 26)

Of these eight braced frames, hand calculations, supplemented with excel spreadsheet calculations were performed to determine the distribution of the lateral loads in the particular frames. These calculations included wind loads in both the North-South and East-West directions and likewise with seismic loads. Direct and torsional shear were calculated under these conditions which yielded a total shear for each braced frame. The torsional shear was calculated per the eccentricity generated between the offset of the center of mass and rigidity with respect to the loading direction. For simplicity and conservation, the eccentricity was calculated at the 8th level, of which all of the brace frames exist. Furthermore, as explained earlier, only these eight braced frames were evaluated for because they were either normal or parallel to the loading directions, the others were at odd angles and not evaluated in this report.

Braced Frame Stiffness			
Frame	Displacement	K (k/in)	Relative Stiffness K
BF6	1.513373	66.08	18.69
BF7	0.959372	104.23	29.49
BF8	2.109039	47.41	13.41
BF9	6.204556	16.12	4.56
BF10	2.185491	45.76	12.94
BF11	3.801471	26.31	7.44
BF12	4.786888	20.89	5.91
BF13	3.744502	26.71	7.55

Table 13 - Table of relative stiffness of highlighted braced frames



Figure 12 - Plan of level 6 highlighting the braced frames

E-W Wind Load Distribution to Braced Frames								
Frame	K (k/in)	Total Lateral Load	e (ft)	d (ft)	$k*d^2$	Direct Shear (k)	Torsional Shear (k)	Total Shear (k)
BF6	66.08	379.4	1.921	11.214	8309.811	0	1.12	1.12
BF7	104.23	379.4	1.921	37.9432	150058.5	0	6.09	6.09
BF8	47.41	379.4	1.921	51.6307	126382.2	114.65	3.70	118.35
BF9	16.12	379.4	1.921	23.714	9065.143	38.98	0.58	39.56
BF10	45.76	379.4	1.921	46.938	100817.3	110.66	3.25	113.91
BF11	26.31	379.4	1.921	37.9432	37878.15	0	1.51	1.51
BF12	20.89	379.4	1.921	23.714	11747.57	50.52	0.75	51.27
BF13	26.71	379.4	1.921	-37.536	37633.09	64.59	-1.52	63.08
N-S Wind Load Distribution to Braced Frames								
Frame	K (k/in)	Total Lateral Load	e (ft)	d (ft)	$k*d^2$	Direct Shear (k)	Torsional Shear (k)	Total Shear (k)
BF6	66.08	321.6	15.611	3.095	632.982	108.08	4.27	112.35
BF7	104.23	321.6	15.611	21.3242	47395.62	170.48	46.42	216.91
BF8	47.41	321.6	15.611	35.012	58117.08	0	34.67	34.67
BF9	16.12	321.6	15.611	7.095	811.4651	0	2.39	2.39
BF10	45.76	321.6	15.611	30.319	42064.5	0	28.98	28.98
BF11	26.31	321.6	15.611	21.3242	11963.72	43.03	11.72	54.75
BF12	20.89	321.6	15.611	7.095	1051.582	0	3.10	3.10
BF13	26.71	321.6	15.611	-54.155	78334.13	0	-30.21	-30.21
E-W Seismic Load Distribution to Braced Frames								
Frame	K (k/in)	Total Lateral Load	e (ft)	d (ft)	$k*d^2$	Direct Shear (k)	Torsional Shear (k)	Total Shear (k)
BF6	66.08	610	1.921	11.214	8309.811	0	1.80	1.80
BF7	104.23	610	1.921	37.9432	150058.5	0	9.79	9.79
BF8	47.41	610	1.921	51.6307	126382.2	184.33	5.95	190.29
BF9	16.12	610	1.921	23.714	9065.143	62.68	0.93	63.61
BF10	45.76	610	1.921	46.938	100817.3	177.92	5.22	183.14
BF11	26.31	610	1.921	37.9432	37878.15	0	2.43	2.43
BF12	20.89	610	1.921	23.714	11747.57	81.22	1.20	82.43
BF13	26.71	610	1.921	-37.536	37633.09	103.85	-2.44	101.41
N-S Seismic Load Distribution to Braced Frames								
Frame	K (k/in)	Total Lateral Load	e (ft)	d (ft)	$k*d^2$	Direct Shear (k)	Torsional Shear (k)	Total Shear (k)
BF6	66.08	610	15.611	3.095	632.982	205.01	8.10	213.11
BF7	104.23	610	15.611	21.3242	47395.62	323.37	88.05	411.42
BF8	47.41	610	15.611	35.012	58117.08	0	65.76	65.76
BF9	16.12	610	15.611	7.095	811.4651	0	4.53	4.53
BF10	45.76	610	15.611	30.319	42064.5	0	54.96	54.96
BF11	26.31	610	15.611	21.3242	11963.72	81.62	22.23	103.85
BF12	20.89	610	15.611	7.095	1051.582	0	5.87	5.87
BF13	26.71	610	15.611	-54.155	78334.13	0	-57.30	-57.30

Table 14 - Wind and seismic distribution to 8 braced frames

Problem Statement

As initially designed, there is little that can be done to improve the structural performance of the USB. All structural systems meet strength and serviceability requirements. Upon completion of construction for the USB, major setbacks in design and construction were evaluated per comments of the designers and contractors. A common setback mentioned by professionals was the delay in schedule and increased cost due to the erection and connection of the superstructure. The complex geometry and intensive connections presented a challenge to those constructing it. The original schedule called for the erection of steel in 32 sequences for building one. As important for any structure, the progress of one sequence directly affects the progress of sequential phases. It was found that the construction of the superstructure put the project behind schedule by 2 months and with incurred additional cost that was withheld by the owner.

The focus of this report is to design a structure that will, in foresight, provide a more feasible and efficient schedule that will not incur additional cost above the contractual value.

Problem Solution

To account for the problem that was just discussed, a concrete building will be designed. This will include a two way flat plate floor system and a shear wall – moment frame interactive lateral system. Per technical report 2, a two way flat plate was an alternative floor system under investigation and proved to be the most feasible alternative. The shear walls will be placed at the core and moment frames will be placed evenly through the width and length of building to help resist torsional loads. As previously mentioned, only levels 4 through the Roof will be considered for redesign.

It is intended that the construction of the concrete system will yield a more reliable and efficient construction sequence. A concrete system may cost more initially but the assumption that the efficiency of the construction will help decrease the overall concrete structure schedule.

In addition, since the steel truss system was a vital part of resisting gravity loads on the cantilevers, it is appropriate to design a concrete truss that still meets strength, and more important serviceability requirements.

Structural Depth Study

Design Goals -

To allow for a successful redesign of an existing structure it is important to describe the intended goals to ensure that tasks are met. The goals will be flexible in order properly adjust for unforeseen results.

The first goals to meet are the strength and serviceability criteria defined by the ASCE7-05 and ACI 318-08. They are the following:

1. Meet strength requirements for all gravity and lateral members.
2. Meet deflection requirements for the floor system; immediate and long term.
3. Meet displacement and story drift requirements for the lateral members.

The more specific goals for this redesign fall within the entire scope of the construction process and are as follows:

1. Design a gravity and lateral system that will produce a more manageable and efficient schedule to, one, avoid construction delays and two, reduce incurred costs from delayed schedules.
2. Design a sufficient concrete truss to resist gravity loads on the cantilever upper story cantilever.

Methodology –

In order to produce results that are reliable, multiple methods were used to yield results that were compared to each other when applicable. This was a combination of hand calculations and computer programs. Such results can be found in the Appendix. The following programs were used for their accompanying detail:

1. **ETABS v9.7.3** – This program was used primarily for the lateral system analysis and design. The model was loaded from loads determined from hand calculations and EXCEL. Sections cut design values were taken from the analyzed model and used to design particular members
2. **spSlab** - This program was used to produce preliminary design values and output for individual equivalent frames of investigation
3. **RAM Concept V8i** – This program was used to model two individual levels, 6 and 8. They produce design output, included all required slab and beam reinforcement.
4. **SpColumn** - This program was used to produce column interaction diagrams for designed gravity columns, lateral columns, and shear walls. Loading for these particular members were applied to the interaction diagram to check for adequate capacity.
5. **EXCEL** – This program was used on multiple occasions for organization, detailed and redundant calculations.

Materials –

Concrete	
User	Strength
Foundations	3000 psi
Elevated Slabs	6000 psi
Gravity Columns	4500 psi
Lateral Columns	8000 psi
Shear Walls	8000 psi

Table 15 - List of concrete materials used

Code and Specification Compliance –

The following codes were referenced when design the structure of the USB.

1. International Building Code 2006
2. ASCE7-05
3. ACI 318-08

Design Load Combinations –

The following load combinations were considered in the design of the structure, as per ASCE7-05 §2.3.2 Basic Combinations. They are as follows:

1. $1.4 D$
2. $1.2 D + 1.6 (L \text{ or } S)$
3. $1.2 D + 1.6(Lr \text{ or } S) + L$
4. $1.2 D + 1.6W + L$
5. $1.2 D + E + L + 0.2S$
6. $.9 D + 1.6 W$
7. $.9 D + E$

Gravity System –

Gravity Loads

ASCE7-05 Table 4-1 *Minimum Uniformly Distributed Live Loads, L_o , and Minimum Concentrated Live Loads* was used to compare the design loads used by the original designer and the loads adopted for this project.

Likewise, superimposed dead determined by the original designer were also used for this project. There are as follows in Table 16.

Provided Superimposed Dead Loads and Live Loads			
Locations	Superimposed Dead Load (psf)	Design Live Loads (psf)	ASCE7-05 Live Loads (psf)
Garage	35	50	40
Planetary Robotics	15	150	125
Loading Dock	5	250	250
Storage	35	125	125
Classroom	35	40	40
Halls, Assembly, Public Areas	35	80	80
Office, Meetings Rooms	35	50	50
Mechanical and Machine Room	75	100	100
Roof	35	30	20
Green Roof 1	35	60	60
Garage Roof	200	100	100
Green Roof 2	200	30	60
Mechanical Roof	35	50	50
Bridge 1	75	100	100
Roof Pavers	50	100	N/A
Roof River Rocks	55	30	N/A

Table 16 - Table of provided superimposed dead loads and live loads

Self-Weights

All structural elements within the scope of the redesign of the USB structure were assigned calculated self-weight dead load. All of the concrete used is Normal Weight Concrete that was assigned a mass of 150 PCF. Such elements include the slabs, columns, beams, and shear walls. Reinforcement is included in that mass. The mass of the façade was assigned as a line load on the slab edges as 200 PLF. This value was calculated by its entire assembly as a PSF and multiplied by the story height, yielding PLF.

Design Process

Redesigning a steel composite floor system to a two way flat plate concrete system involves many initial layout considerations. As rule of thumb, two way flat plate construction is most economical with spans of 15' – 20' (Wright and MacGregor p. 606). This is dependent on the compressive strength, f'_c , and the amount of reinforcing bars. The rearranging of columns was an iterative process to find the most efficient system.

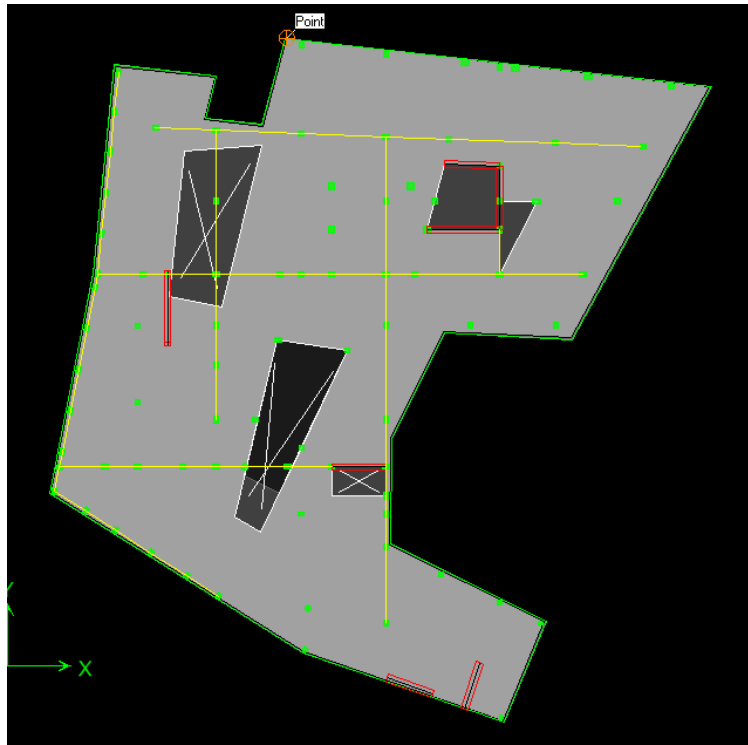

Figure 14 - Final Column layout for Level 9

Two Way Flat Plate Design

The initiative to use a two way flat plate was to help reduce cost, maintain a smaller plenum space than the existing system in order to lower the floor to floor height, and to simplify the formwork. ACI 318 § 9.5.3.2 grants the use of Table 9.5(c) for minimum slab thickness. With an f_y of 60,000 psi and with edge beams a preliminary thickness of $l_n/33$ was used. At the most extreme dimension of 30', $t = 11.4''$; 12'' thickness was chosen as the slab thickness.

spSlab Analysis –

spSlab was used to produce initial design values and design output. A couple typical frames were analyzed to verify hand calculations. The following frame along column line G18 on Level 4 was analyzed in this program.

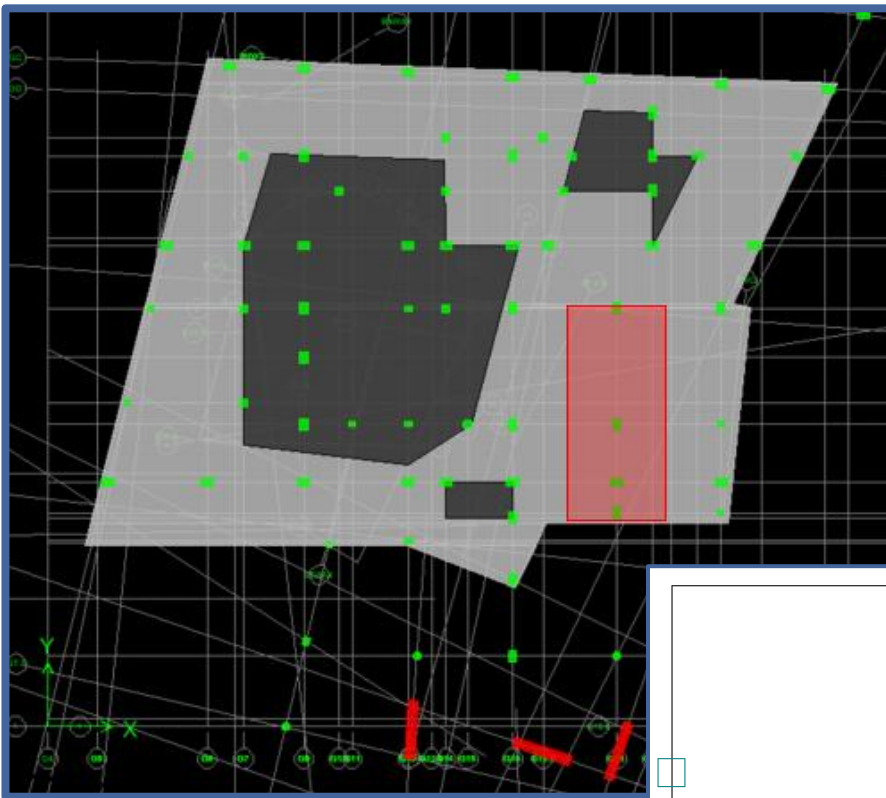

Image 15 - ETABS Level 4 – Column Line G18 highlight

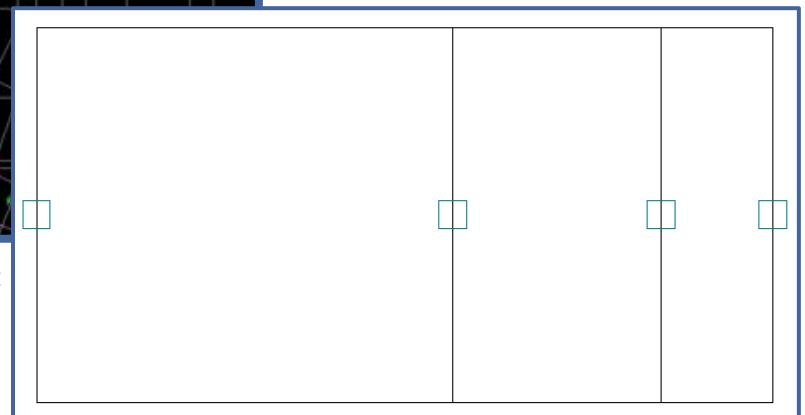

Image 16 - spSlab Level 4 – Column Line G18

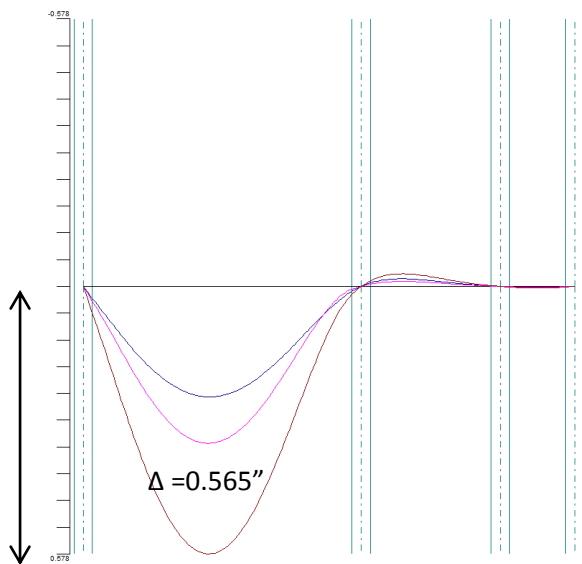

Image 17 - spSlab Level 4 – Column Line G18 Column Strip Reinforcement Plan

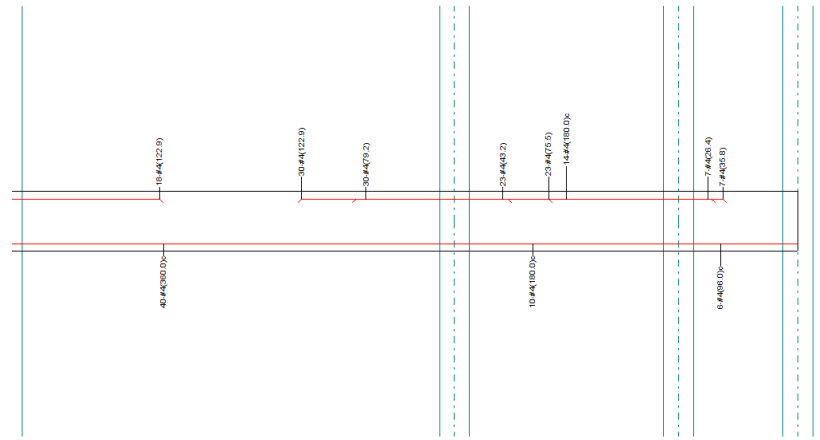

Image 18 - spSlab Level 4 – Column Line G18 Dead, Live, and Total Load Deflection

spSlab's results provided a baseline of comparison for the use of other programs. The total load deflection of 0.565" was within the allowable limit of 0.675" ($L/480$). With this information, a 12" slab thickness was used to further analyze an entire floor slab.

RAM Concept Analysis –

RAM Concept was used to analyze entire floor system. Once again this was an iterative process as column, shear wall, and moment frame beams all changed sizes and location throughout the design. Due to time constraints, only two floors were fully modeled in this program, levels 6 and 8. Level 6 was chosen because of it included many elements that effect the design of the slab; these elements include openings, different column sizes, sufficient edge beams and shear walls. Level 8 was chosen because it includes part of the concrete truss

RAM Concept has the ability to automatically assign spans, column strips, and middle strips but it was important to double check these assignments as some were not logical and need user assignment. The elements were assigned a compressive strength, f'_c , of the appropriate material mentioned earlier.

RAM Concept was programed to follow ACI 318-08 code initial, long term, and sustained service design, strength design, and ductility design. The slabs were loaded with (4) different cases. They include self-weight dead load, superimposed dead load, reducible live load, and cladding. The program calculates the live load reduction factor per ASCE7-05 § 4.8.1. The program was set to use #5 bars for column and middle strip reinforcement and #4 bars for shear reinforcement. Figures 20 and 21 show the designed two way reinforcement of levels 6 and 8. Images 19-22 display the floor and member layout as wells as the maximum the slab sees.

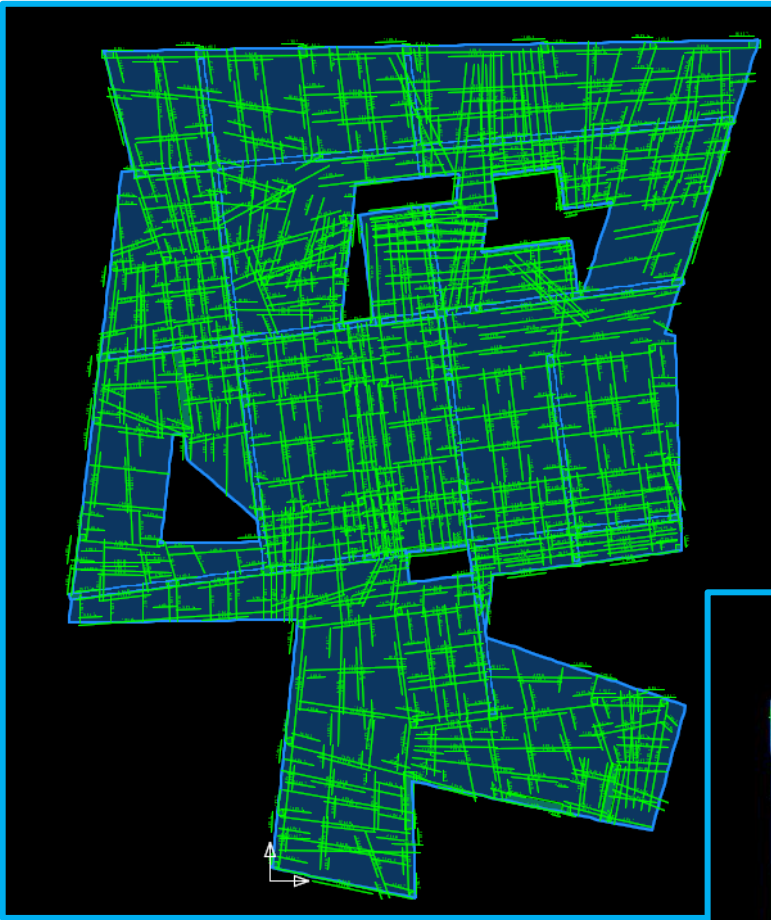

Image 20 - RAM Concept- Level 6 reinforcement plan

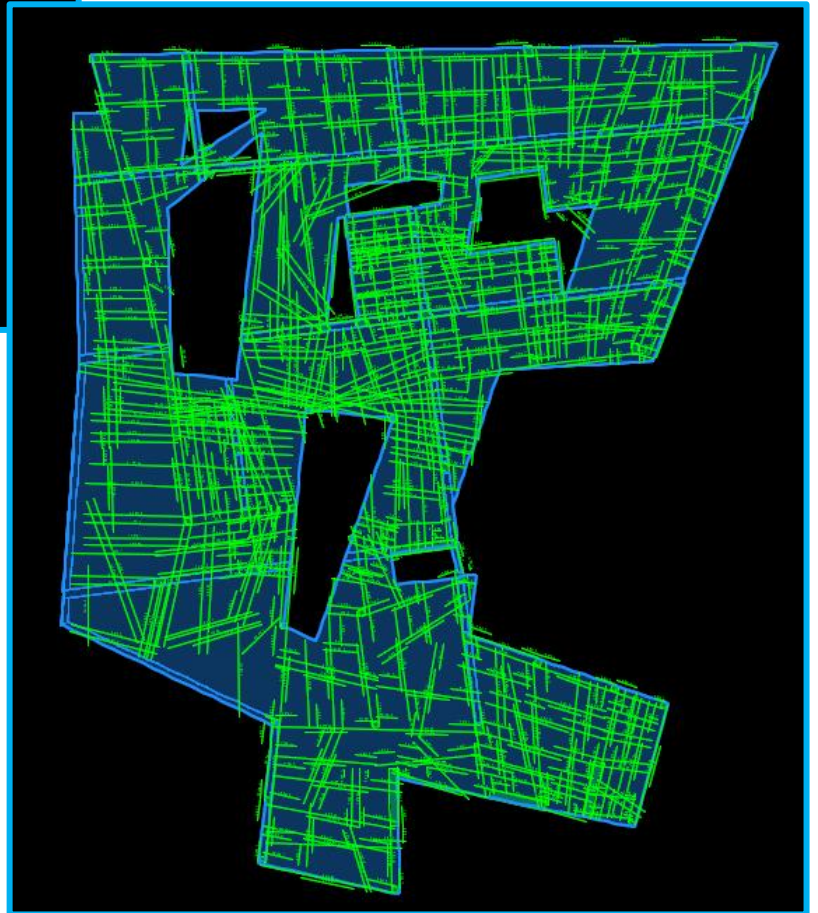
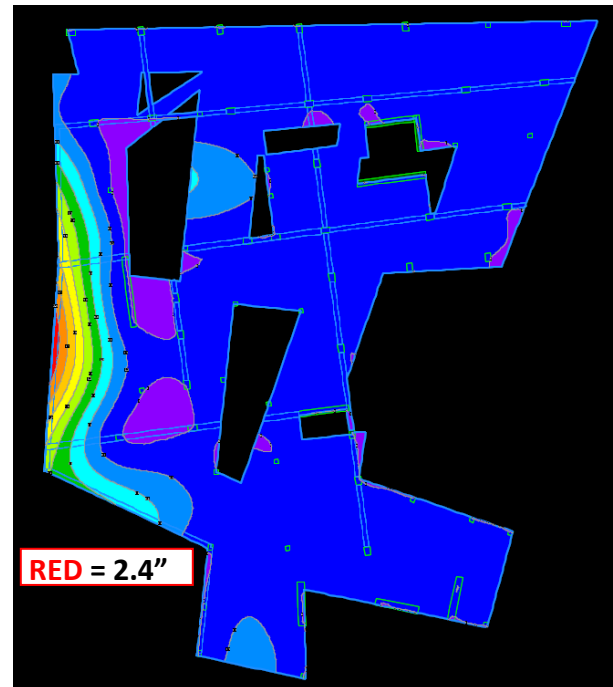
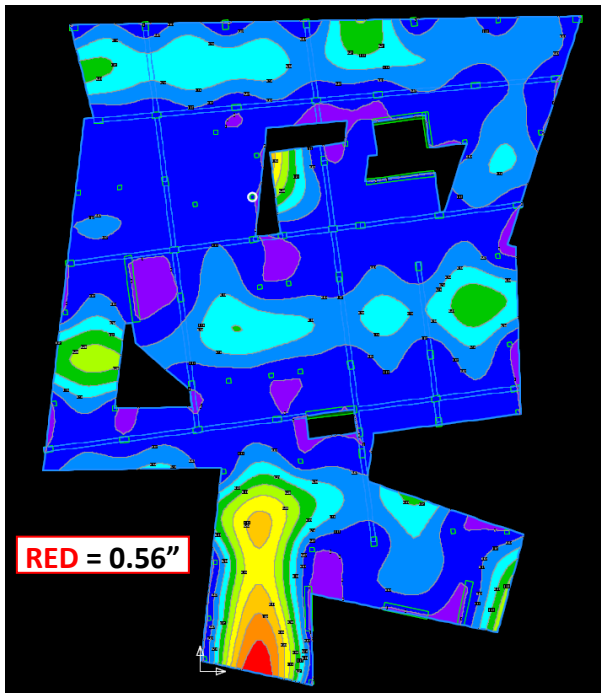
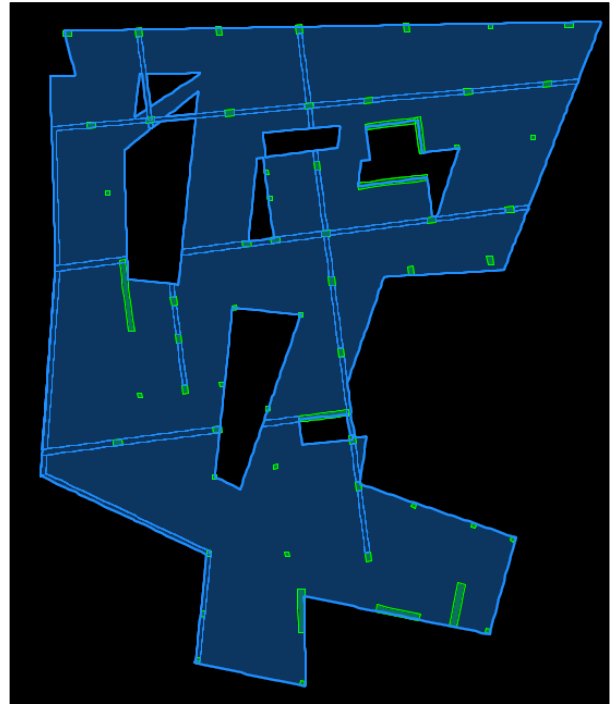
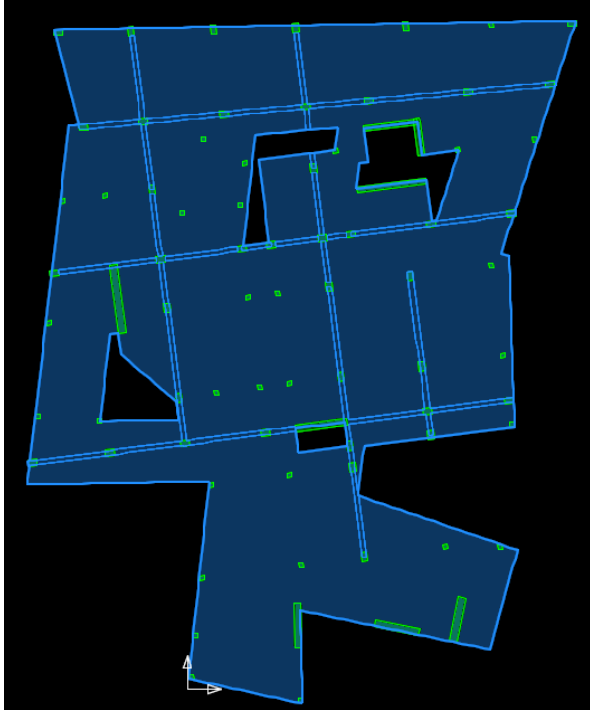

Image 20 - RAM Concept- Level 8 reinforcement plan



Images 19-22 - RAM Concept- Level 6 (left) and level 8 (right). The top photos show the member layout and the bottom shows the max deflection

Edge Beam Design

In this two way flat plan gravity system, moments are distributed to the edge of the slabs. These moments are then distributed to the columns. This distributed moment generates twisting moments, torque, or, commonly, torsional moment. This moment causes shearing stresses on cross-sectional planes along the member's axis. It is important to design a member to resist these torsional moments. The detail of the reinforcement is what helps the cross section resist these moments and works similarly to the way shear reinforcement works.

Process

Due to time limitations, specific areas where edge torsional moments were thought to be of significant design were the areas that were designed. It was intended to keep a relative shallow beam depth but due to the significant spans, this was hard to maintain.

Design values for the spans under consideration were taken from the RAM concept model. Distributed gravity loads were used to find the maximum shear at each column face and a distributed moment was used to find the maximum torque at each column face. ACI318-08 §12.5 was then used to design the members.

ACI318-08 §11.5.2.2 states that the maximum T_u value can be taken as 4 times the threshold torsion due to redistribution effects. The remaining torsion that the beam does not take is redistributed to the slab. For example, the torsion on a 27' design span experiences 171 'k but only took 37.6 'k (4x the threshold). This remaining 133 'k is redistributed to the slab through the equivalent frame's column strip and middle strip. This would need to be checked to see if there is sufficient reinforcement in the slab with this additional load. Due to time constraints, this calculation was not performed but would need to be investigated. The following image displays the design summary of an edge beam spanning 27' at the negative moment region. Supporting calculations can be found in Appendix A.

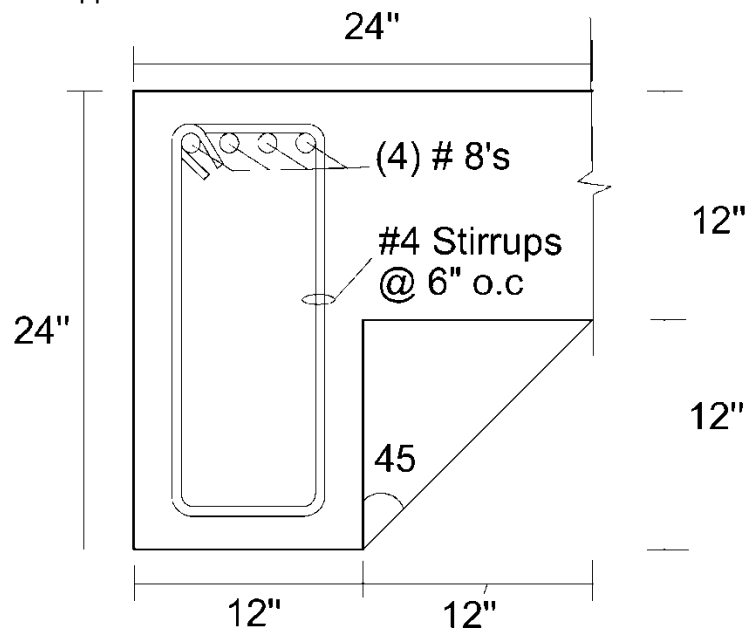

Image 22 – Designed edge beam section

Concrete Truss Design-

Overview/Layout

The intent of the concrete truss is to resist gravity loads on levels 8-Roof (Figure 23) on the west elevation and level 6-7 on the south elevation (Figure 23) which are part of a cantilever. A Vierendeel truss design was chosen to maintain the flexibility of usable space within the building. The existing structural system uses a steel truss system, which was used as the initial spatial layout of the new concrete truss system. This truss's

layout was not finalized until the final column layout was determined. This truss system is integrated with moment frame columns, as well as shear walls. The truss columns and beams use an f'_c of 6,000 psi (as seen as the blue and green members in Figure 25). The shear walls and moment frame columns can be identified by the magenta color in Figure 25. First, hand calculations were performed on one particular frame of the truss, along column line GO. The Portal Frame analysis was used to determine design values to design member sections (Figure 24). These calculations in their entirety can be found in Appendix B.



Image 23: Image of west façade with highlighted cantilever

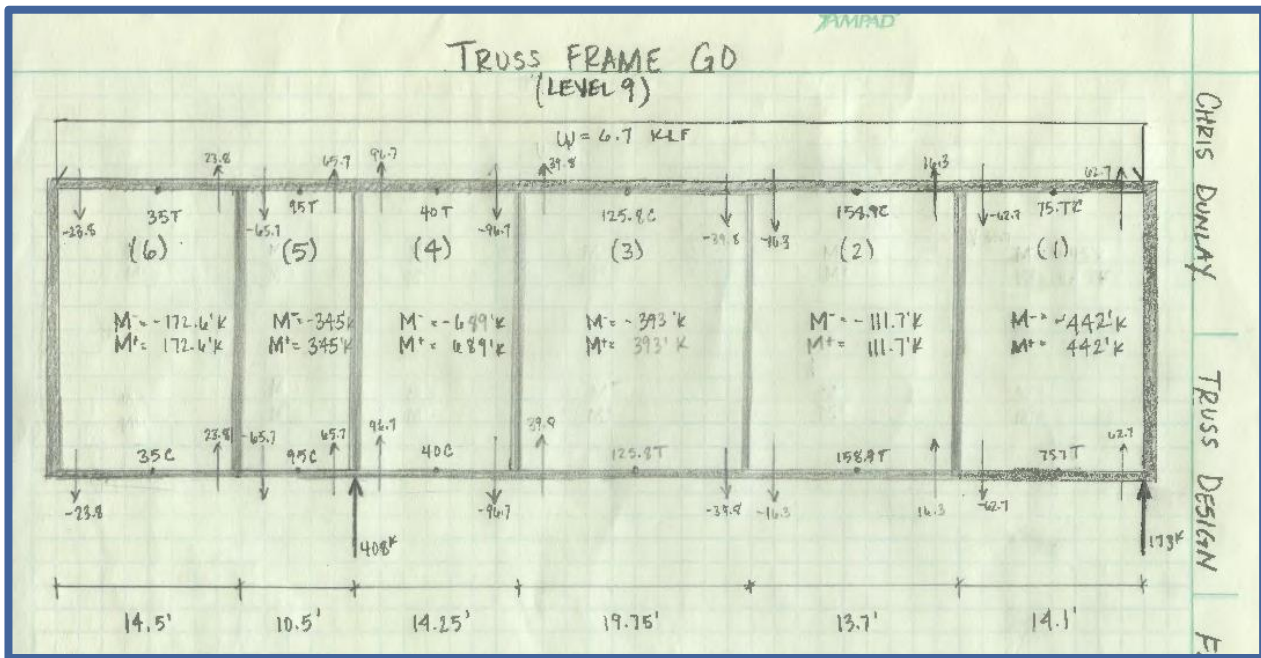

Figure 24 : Portal Frame analysis design values

Next, one truss frame along column line GO was modeled in SAP2000. The main goal of this program modeling was to compare and verify deflections and the design values with the hand calculations. Once the SAP2000 verified the design values, the design hand calculations sections were modeled as an entire truss system in ETABS. Once again the purpose of this ETABS modeling was to check deflections of the entire truss system. The following images show the layout of the entire system.

The following chart shows the allowable deflection vs. actual deflections for frame GO. It should be noted that the allowable deflection limits are per The International Building Code 2009 §1604.3 Serviceability. In addition, footnote (i) was taken into account; stating 'For cantilever members, L should be taken as twice the length of the cantilever. The following images and tables show the deflection results from truss frame GO

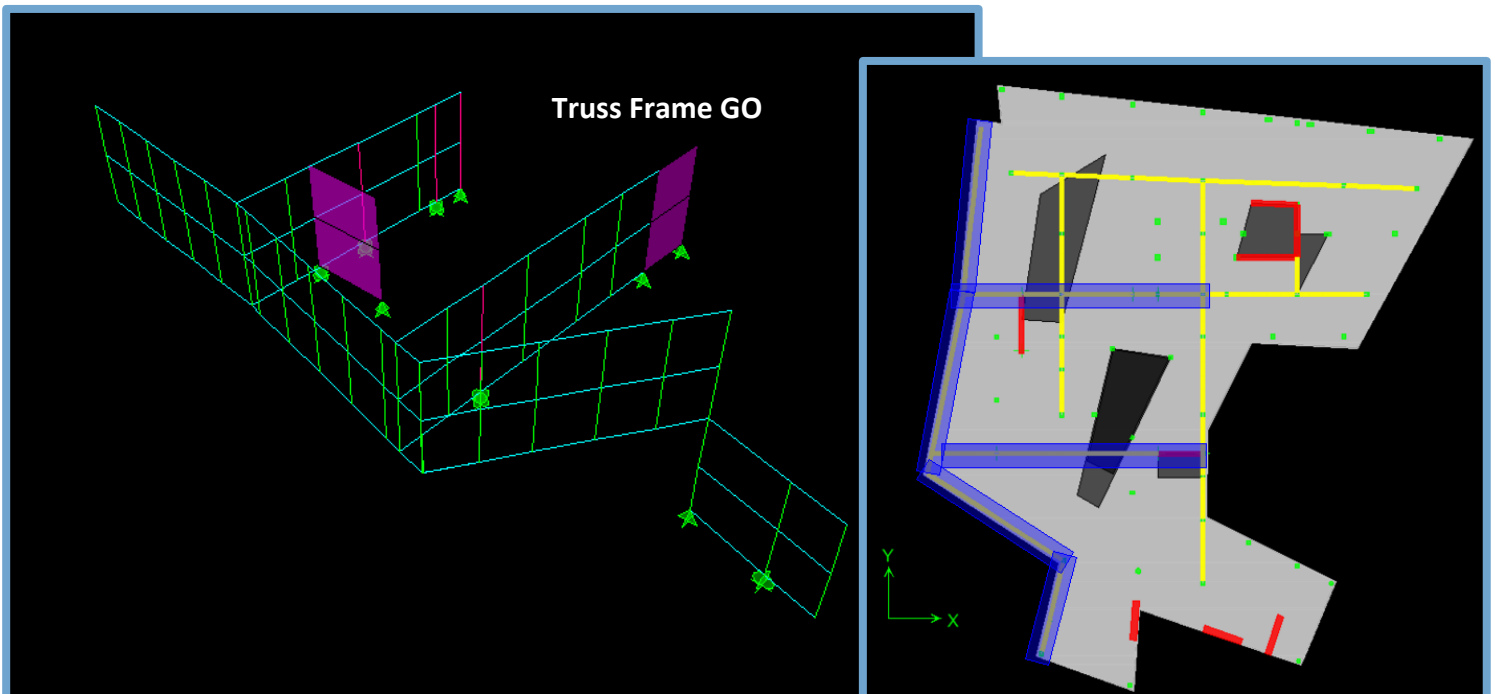

Figure25 : 3D ETABS Model of truss

Figure 26: Level 8 -ETABS with highlighted truss in blue.

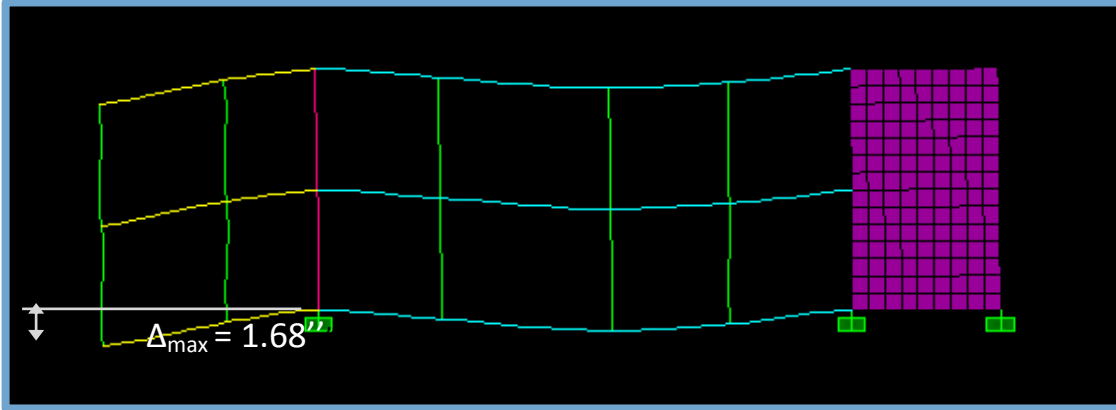

Figure 27 : Truss frame GO Total Load deflection

Allowable Deflection			
	Span	Live (in)	Total Load (in)
B/W Spans	61.8 ft	2.06	3.09
Cantilever	25 ft	1.6667	2.5

Table 17: Allowable an actual deflections of Frame GO

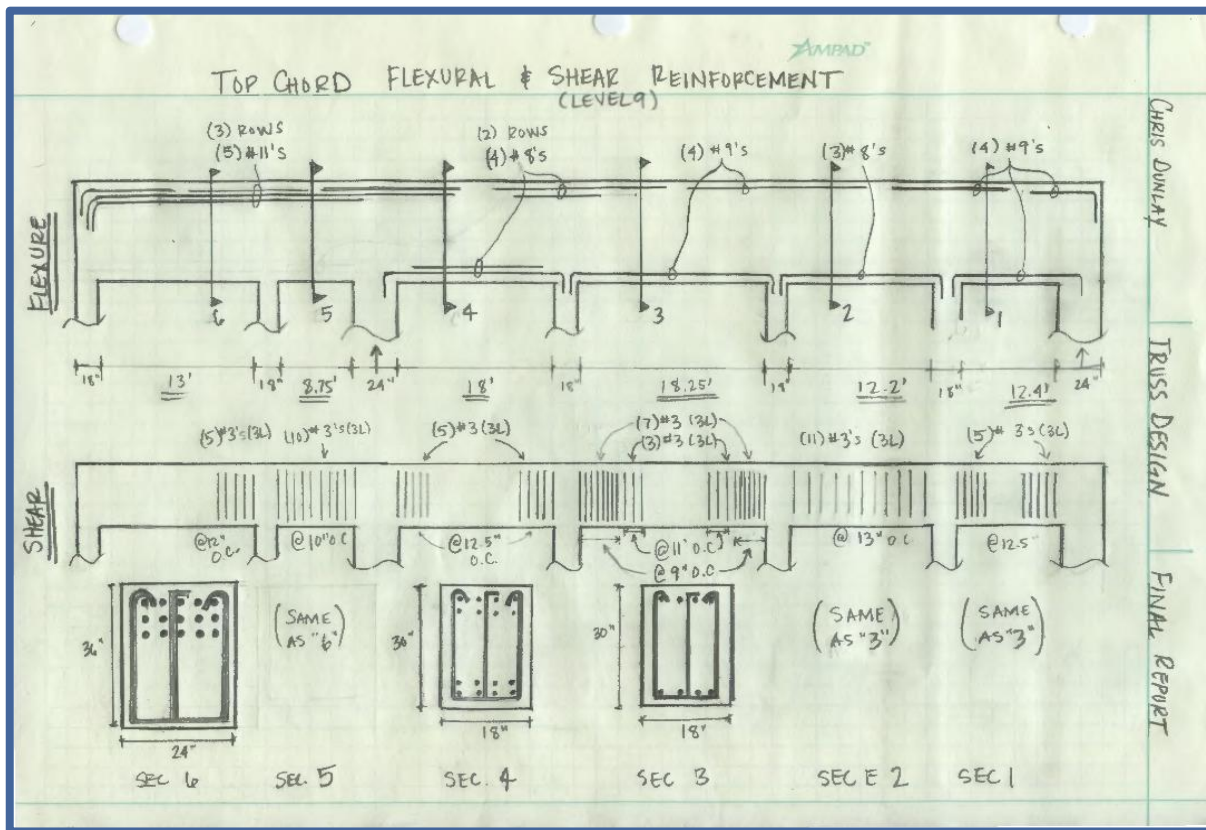

Figure 28 Hand drawn sections of flexural and shear

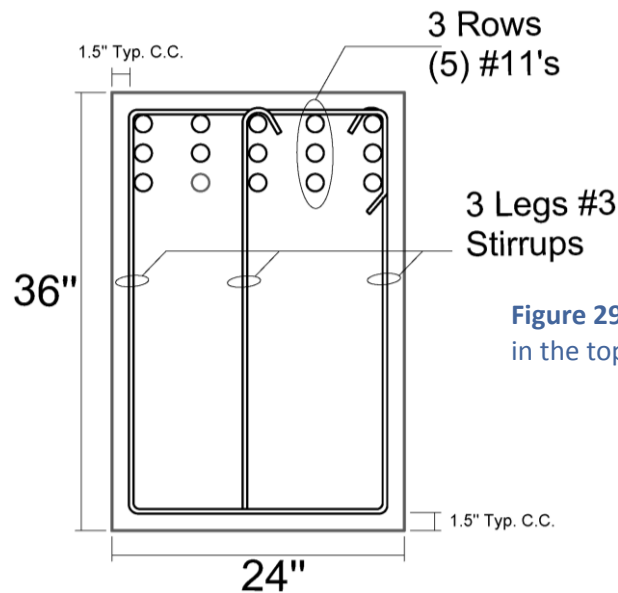

Figure 29 - AutoCAD section of the beams used in the top chord of the truss frame GO

Design Process

Strength

The portal frame method was used to determine all preliminary design loads. The accompanying computer programs verified these results with little deviation. The individual beams were then estimated an area of flexural steel (A_s) and checked against minimum area of steel ($A_{s,min}$) per ACI §10.5.1. The following equation was used to estimate the area of steel.

$$A_{s,Req} \approx \frac{M_u}{4d}$$

Note: This is under the assumption $\rho \leq 0.00125$

Each design section was the checked to see if the capacity (ϕM_n) is greater than the ultimate moment (M_u), where (ϕM_n) =

$$\phi M_n = \phi A_s f_y (d - a/2)$$

In these report calculations, the design process was assuming that steel yields and it was necessary to check this assumption upon the completion of every design section. In addition, the comparison of the strain of steel to the net tensile strain in the extreme tension steel ($\epsilon_t = 0.005$) as this is dependent on the use of $\phi = 0.9$ (ACI §9.3.2 and 10.3.4)

Serviceability

Along with strength, serviceability was important to check, as it could control the design. Chapter 9 of the ACI was used to calculate the deflections of the truss. Four different cases were analyzed and are as follows:

Immediate Deflection

1. $\Delta_{i,d}$ - Immediate Full Dead Load
2. $\Delta_{i,sus}$ - Immediate Full Dead Load + %50 Live Load
3. $\Delta_{i,d + l}$ - Immediate Full Dead Load + Full Live Load
4. $\Delta_{i,l} = (\Delta_{i,d + l}) - (\Delta_{i,d})$ Immediate Live Load

Long term deflections were calculated by multiplying the immediate deflections by λ_{Δ} , per ACI § 9.5.2.5 where;

$$\lambda_{\Delta} = \frac{\xi}{1 + 50\rho'}$$

These calculations required the use of effective moment of inertia per ACI § 9.5.2.3 stating:

$$I_e = \left(\frac{M_{cr}}{M_a}\right)^3 I_g + \left[1 - \left(\frac{M_{cr}}{M_a}\right)^3\right] I_{cr} \text{ where;}$$

$$M_{cr} = \frac{f_r I_g}{y_t} \quad f_r = 7.5 \lambda \sqrt{f'_c}$$

Reinforcement Detailing

As the design of this truss is only vertical and horizontal members (no diagonals) it is important to detail the beam column joint accurately to ensure that they maintain the rigidity they are assumed to have in design. For this reason, bar cut offs were not commonly used but instead top and bottom bars ran the length of the truss frame. ACI § 12.2 – 12.5 was used in the detailing of the reinforcement and can be found in the design Appendix B.

Summary and Conclusions

In order to maintain the intended architecture of the original design if the structure were to change to concrete, this truss provides a viable solution to resist gravity loads. The trusses met all the criteria for flexural and shear resistance. Through an iterative process, the cantilever section was designed through the controlling of deflections. All other frames met criteria for deflection as well. This system will add additional weight to the structure and will need additional formwork for the chords. It should be noted that the detailing of the trusses for lateral loads is very important but does not fall into the scope of this project.

Lateral System

Design Goals

The original structure utilized a dual system of steel braced frames through the core of the building and concrete shear wall on south portion of the building. The erection and detailing of the steel braced frames contributed greatly to the delay of the schedule, as mention in the problem statement. Therefore, the proposition of changing the lateral resisting system to core shear walls and concrete moment frames was made with the following goals:

1. Due to the horizontal and vertical irregularities in the structure, concrete moment frames spaced throughout the building in both directions would help resist the torsion in the structure.
2. The utilization of a monolithic structure would allow the building to be constructed in an even sequence allowing for a more efficient schedule.
3. This system does not include diagonal members which allows for a more efficient use of the space inside of the building.

Methodology

The lateral loads, both wind and earthquake, were analyzed by the Analytical Procedure (ASCE7 – 05 § 6.5) and by the Equivalent Lateral Force Procedure (ASCE7-05 §12.8) respectively. The following methods were used in analyzing and designing the lateral resisting system.

1. **Hand Calculations** – Design criteria values were calculated by hand. These values include wind and earthquake design coefficients. In addition, a few lateral resisting members were designed by hand, including moment frame columns, beams, and shear walls.
2. **EXCEL**- Design wind pressures and story forces were calculated in EXCEL, along with building weight, story forces, story shear, base shear, and overturning moment for earthquake loads.
3. **ETABS v9.7.3** - Design story forces from excel were applied to the modeled lateral system in ETABS. This program provided information such as periods, moments and shears in lateral resisting members; base shear and overturning moment values. From these values, relative stiffness was used to design the lateral resisting members.
4. **spColumn** – This program was used to check the design combined loading capacity of a section vs. the design values from hand calculations and ETABS.

Lateral Loads – Wind

Analysis of wind loads follow ASCE7-05 Chapter 6 and uses § 6.5, Analytical Procedure. The site of this project was important in analyzed the structure as the building sees different winds from different directions. Due to the topography of the site, wind from the West was assigned an 'Exposure Category' C and all other directions were assigned B. In addition, since the South elevation of the building has the entire height of the building exposed (Base – Roof), it will accumulate pressures at all levels, as opposed to the other elevations that only

have level 3 to Roof exposed). The following are tables breakdown the forces at each level of each elevation. Note: Since ASCE7-05 is being used, controlling load combination includes a factor of (1.6) for wind.

Item	Variable	Value	ASCE7-05 Location
Basic Wind Speed	V	90	mph
Importance Factor	I	1.15	Fig. 6-1
Exposure Category	-	C	From the West
	-	B	From all others
Directionality Factor	Kd	0.85	Table 6-4
Topographic Factor	Kzt	1	6.5.7.1
Intensity of Turbulence (N/S)	Iz	0.2702 15	Eq. 6-5
Intensity of Turbulence (E)	Iz	0.2702 15	Eq. 6-5
Intensity of Turbulence (W)	Iz	0.1801 43	Eq. 6-5
Integral Length Scale of Turbulence	Lz	394	Eq. 6-7
Integral Length Scale of Turbulence	Lz	394	Eq. 6-7
Integral Length Scale of Turbulence	Lz	567	Eq. 6-7
c (N/S)	c	0.3	Table 6-2
c (E)	c	0.3	Table 6-2
c (W)	c	0.2	Table 6-2

Item	Variable	Value	ASCE7-05 Location
I (N/S)	L	320	Table 6-2
I (E)	L	320	Table 6-2
I (W)	L	500	Table 6-2
Zmin (N/S)	Zmin	61.8	Table 6-2
Zmin (E)	Zmin	61.8	Table 6-2
Zmin (W)	Zmin	61.8	Table 6-2
€ (N/S)	€	0.33	Table 6-3
€ (E)	€	0.33	Table 6-4
€ (W)	€	0.2	Table 6-5
Background Response Factor (N/S)	Q	0.811	Eq. 6-6
Background Response Factor (E)	Q	0.805	Eq. 6-6
Background Response Factor (W)	Q	0.836	Eq. 6-6
Gust Factor (N/S)	G	0.818	Eq. 6-4
Gust Factor (E)	G	0.815	Eq. 6-4
Gust Factor (W)	G	0.848	Eq. 6-4

Table 18 : Design data, coefficients, and values for Main Wind Force Resisting System

WEST Direction										
Floor	Ht.	Ht. Above	Kz	qz	Wind Pressure (psf)		Total Pressure	Net Force	Story Shear	Overturning Moment (ft-K)
					Windward	Leeward				
Roof	13	95	1.2475	25.3	17.1	-10.7	27.9	37.67 K	37.67 K	3578.2
9	13	82	1.216	24.6	16.7	-10.7	27.4	37.84 K	75.51 K	3103.2
8	13	69	1.166	23.6	16.0	-10.7	26.7	37.25 K	112.76 K	2570.5
7	13	56	1.114	22.6	15.3	-10.7	26.0	36.32 K	149.08 K	2034.0
6	13	43	1.055	21.4	14.5	-10.7	25.2	35.35 K	184.43 K	1520.0
5	13	30	0.98	19.9	13.5	-10.7	24.2	34.25 K	218.68 K	1027.4
4	13	17	0.87	17.6	12.0	-10.7	22.7	32.84 K	251.52 K	558.3
3	17	0	0.85	17.2	11.7	-10.7	22.4	30.84 K	282.37 K	0
Base	0	0	0	0	0	0	0		282.37 K	14391.7
Factored Base Shear									451.78 K	
Factored Overturning Moment										23,026.7 ft- K

EAST Direction										
Floor	Ht.	Above Grade Ht.	Kz	qz	Wind Pressure		Total Pressure	Net Force (K)	Story Shear (K)	Overturning Moment (ft-K)
					Windward	Leeward				
Roof	13	95	0.9775	19.8	12.9	-10.3	23.2	31.40 K	31.40 K	2983.2
9	13	82	0.936	19.0	12.4	-10.3	22.7	31.55 K	62.95 K	2587.1
8	13	69	0.886	18.0	11.7	-10.3	22.0	30.80 K	93.76 K	2125.5
7	13	56	0.874	17.7	11.6	-10.3	21.9	29.91 K	123.66 K	1674.9
6	13	43	0.775	15.7	10.2	-10.3	20.5	29.69 K	153.35 K	1276.5
5	13	30	0.7	14.2	9.3	-10.3	19.6	27.91 K	181.26 K	837.3
4	13	17	0.59	12.0	7.8	-10.3	18.1	26.56 K	207.82 K	451.5
3	17	0	0.57	11.6	7.5	-10.3	17.8	24.63 K	232.45 K	0
Base	0	0	0	0	0.0	-10.3	0		232.45 K	11936.0 ft- K
Factored Base Shear									371.92 K	
Factored Overturning Moment										19,097.6 ft- K

Table 19: Design story shear and moments for wind from the east and west direction

South Direction										
Floor	Ht.	Above Grade Ht.	Kz	qz	Wind Pressure		Total Pressure	Net Force (K)	Story Shear (K)	Overturning Moment (ft-K)
					Windward	Leeward				
Roof	14	128	1.06	21.5	14.1	-6.6	20.7	27.37 K	27.37 K	3503.5
9	14	114	1.032	20.9	13.7	-6.6	20.3	26.88 K	54.25 K	3064.2
8	14	100	1.01	20.5	13.4	-6.6	20.0	26.49 K	80.74 K	2649.3
7	14	86	0.994	20.1	13.2	-6.6	19.8	26.21 K	106.96 K	2254.3
6	14	72	0.92	18.6	12.2	-6.6	18.8	24.91 K	131.87 K	1793.7
5	14	58	0.868	17.6	11.5	-6.6	18.1	24.00 K	155.87 K	1392.0
4	14	44	0.86	17.4	11.4	-6.6	18.0	23.86 K	179.73 K	1049.8
3	19	25	0.57	11.6	7.6	-6.6	14.2	25.47 K	205.20 K	636.8
2	15	10	0.57	11.6	7.6	-6.6	14.2	20.11 K	225.31 K	201.1
1	10	0	0.57	11.6	7.6	-6.6	14.2	13.41 K	238.72 K	0.0
Base	0	0	0	0	0.0	-6.6	0		238.72 K	16544.8 ft-K

Factored Base Shear **381.95 K**

Factored Overturning Moment **26,149.9 ft-K**

North Direction										
Floor	Ht.	Above Grade Ht.	Kz	qz	Wind Pressure		Total Pressure	Net Force (K)	Story Shear (K)	Overturning Moment (ft-K)
					Windward	Leeward				
Roof	14	103	0.9975	20.2	13.2	-6.6	19.9	26.27 K	26.27 K	2706.2
9	14	89	0.957	19.4	12.7	-6.6	19.3	25.56 K	51.84 K	2275.1
8	14	75	0.91	18.4	12.1	-6.6	18.7	24.74 K	76.57 K	1855.3
7	14	61	0.894	18.1	11.9	-6.6	18.5	24.46 K	101.03 K	1491.9
6	14	47	0.795	16.1	10.5	-6.6	17.2	22.72 K	123.75 K	1067.8
5	14	33	0.718	14.6	9.5	-6.6	16.2	21.37 K	145.12 K	705.1
4	14	19	0.61	12.4	8.1	-6.6	14.7	19.47 K	164.59 K	370.0
3	19	0	0.57	11.6	7.6	-6.6	14.2	25.47 K	190.06 K	0
Base	0	0	0	0	0.0	-6.6	0		190.06 K	10471.3 ft-K

Factored Base Shear **304.10 K**

Factored Overturning Moment **16,754.1 ft-K**

Table 20: Design story shear and moments for wind from North and South direction

Upon the completion of computing story pressure, shears, and base shears it can be concluded that wind from the West Direction produces a factored base shear of 452 K. This is a direct correlation to the fact that the west elevation has a more open topography, granting it an Exposure Category C.

Lateral Loads – Earthquake

The analysis of earthquake loads followed guidelines from ASCE7-05 Chapters 11 and 12 and uses §12.8, Equivalent Lateral Force Procedure. Typically, buildings in Northeast, USA are controlled by Wind Forces but the because of the induced weight of the structure, earthquake loads are now a point of interest. Information from the Geotechnical Report was used help calculate design loads of the structure.

Item	Variable	Value	ASCE7-05 Location
Soil Classification	--	C	Table 20.3-1
Occupancy	--	II	Table 1-1
Importance Factor	Ie	1.25	Table 11.5-1
Structural System		Shear Wall-Frame Interactive System	Table 12.2-1 (F)
Spectral Response Acceleration, Short	Ss	0.128	USGS
Spectral Response Accelerations, 1 s	S1	0.06	USGS
Site Coefficient	Fa	1.2	Table 11.4-1
Site Coefficient	Fv	1.7	Table 11.4-2
MCE Spectral Response Acceleration, Short	SMS	0.1536	Eq. 11.4-1
MCE Spectral Response Acceleration, 1 S	SM1	0.102	Eq. 11.4-2
Design Spectral Acceleration, Short	SDS	0.1024	Eq. 11.4-3
Design Spectral Acceleration, 1 s	SD1	0.068	Eq. 11.4-4
Seismic Design Category	SDC	B	Table 11.6-1
Response Modification Coefficient	R	4.5	Table 12.2-1
Deflection Amplification Factor	Cd	4	Table 12.2-1
Approximate Period Parameter	Ct	0.016	Table 12.8-2
Building Height	hn	108	Above Grade
Approximate Period Parameter	x	0.9	Table 12.8-2
Calculated Period Upper Limit Coefficient	Cu	1.7	Table 12.8-1
Approximate Fundamental Period	Ta	1.08	Eq. 12.8-7
Max Period	Cu*Ta	1.84	Sec 12.8.2
Fundamental Period	T	0.8	Eq. 12.8-8
Long Period Transition Period	TL	12	Fig. 22-15
Seismic Response Coefficient	Cs	0.0103	Eq. 12.8-2
Structural Period Exponent	k	1.15	Sec. 12.8.3
Redundancy Factor	r	1	Sec. 12.3.4.1
Building Weight	W	59354	From Building Weights
Base Shear	V	609.55	Eq. 12.8-1

Table 21: Design data, coefficients, and values for earthquake 'Equivalent Lateral Force Procedure' per ASCE7-05 Chapter 11.

Once all design criteria was established, EXCEL was used to compute story forces, shears, and overturning moments. The following is a table that shows these values.

Earthquake - N/S and E/W Directions									
Level	hi (ft)	h (ft)	w (k)	w*hk	CVX	fi (k)	Vi (k)	M (ft-k)	
Roof	13	120	6104	18107029	0.229	135	0	16145	
9	13	107	7001	17148691	0.217	127	135	13634	
8	13	94	7586	14967055	0.189	111	262	10454	
7	13	81	6575	10117326	0.128	75	373	6089	
6	13	68	8469	9730206	0.123	72	448	4916	
5	13	55	4895	3946012	0.050	29	521	1613	
4	13	42	5100	2620574	0.033	19	550	818	
3	17	25	11552	2495841	0.032	19	569	464	
Base	25	0	0	0	0.000	0	588	0	
			Σ	57282	79132735			588 k	54,134 'k

Table 22: Design values for earthquake loads in bot N-S and E-W loads

Summary of Lateral Loads

From the analysis of wind and earthquake loads, it can be determined that earthquake loads control by a factor of 1.22. The existing structure was controlled by wind and reasons for this difference are because of the following:

1. **Decreased Building Height** - Each floor height above grade was decreased by 12" and the third floor decreased by 24". The Wind forces are dependent on the height of each story. With a decrease in story height, the story forces and base shears decrease.
2. **Additional Mass** - With a new concrete structure, the total weight has nearly doubled. This inherently increases the forces at each level and the base shears.

ETABS Analysis

ETABS v9.7.3 is a computer modeling and analysis program developed by Computer and Structures, Inc. For this study, this program will be used to analyze the structure. The following are assumptions made in modeling and analyzing the structure.

- The two way flat plate slab is considered to act as a rigid diaphragm.
- The mass of the slab, walls, columns, and beams were considered in determining the building period (assigning 'Mass Source')
- Self-weights of slabs, walls, columns, beams, superimposed dead, and reduced live loads were calculated when lumping additional mass to the center of mass.
- All moment frame joints are given a rigid end offset of 0.5 to more accurately represent the actual behavior at the joints.
- All walls are meshed at a maximum spacing of 24".
- Walls are modeled as a membrane.
- The moment of inertia of elements in the model are as follows, per ACI § 10.10.4.1:
 - Columns = $0.7 I_g$
 - Walls = $0.35 I_g$
 - Beams = $0.25 I_g$

The compressive strength, f'_c , and modulus of elasticity, E_c , of the elements in the model are as follows:

- Moment Frame Columns : 6 ksi
- Moment Frame Beams: 6 ksi
- Shear Walls: 8 ksi
- Slab: 6 ksi

Earthquake Analysis

Design Considerations

The analysis of the lateral system under earthquake loads must consider the criteria of specific design guidelines found in ASCE7-05 Chapter 11 and 12. The following section will discuss the application of such design guidelines.

ASCE7-05 §12.2.5.10 – Shear Wall-Frame Interactive Systems (R=4.5 Cd=4): See Relative Stiffness Section

ASCE7-05 §12.3.2.1 and 2 – Horizontal and Vertical Irregularities: See Tables () and () below.

ASCE7-05 §12.5.2 – Directional Loading (SDC B) – Structure is permitted to have independently applied loads in each orthogonal direction. Orthogonal interaction effects are permitted to be neglected.

ASCE7-05 §12.2.5.10 – Condition Where Value of β is 1.0 – This building is Seismic Design Category B or C.

ASCE7-05 Tab. 12.6-1 – Permitted Analytical Procedures: Equivalent Lateral Force Analysis is permitted (SDC B)

Horizontal Torsional Irregularity ASCE7-05 Table 12.3-1						
Horizontal Irregularities		X Direction		Y Direction		
	1a. Torsional Irreg.	Δ_{max}	0.003434		Δ_{max}	0.000262
		Δ_{avg}	0.002313		Δ_{avg}	0.000255
		Δ_{max}/avg		1.48 > 1.2 T.I.	Δ_{max}/avg	1.03 < 1.2 Complies
	1.b Extreme Torsional Irreg.	Δ_{max}	0.003434		Δ_{max}	0.000262
		Δ_{avg}	0.002313		Δ_{avg}	0.000255
		$\Delta_{max}/\Delta_{avg}$		1.48 > 1.4 T.I.	$\Delta_{max}/\Delta_{avg}$	1.03 < 1.4 Complies
2. Reentrant Corner Irreg.		N/A		N/A		
3. Diaphragm Discontinuity Irreg.		N/A		N/A		
4. Out-of-Plane Irreg.			Complies		Complies	
5. Non-parallel Systems Irreg.			Complies		Complies	

Table 23 - ASCE7-05 Tables 12.3-1 that describe the type of horizontal irregularities.

Horizontal Torsional Irregularity ASCE7-05 Table 12.3-2			
Vertical Irregularities	X Direction		Y Direction
	1a. Stiffness-Soft Story Irreg.	N/A	N/A
	1.b Stiffness-Extreme Soft Story Irreg.	N/A	N/A
	2. Weight Irregularity	N/A	N/A
	3. Vertical Geometry Irreg.	Complies	Complies
	4. In-Plane Discontinuity Irreg.	N/A	N/A
	5a. Discontinuity in Lateral Strength Irreg. - Soft Story	N/A	N/A
	5b. Discontinuity in Lateral Strength-Extreme Soft Story	N/A	N/A

Table 24 - ASCE7-05 Tables 12.3-2 that describe the type of vertical irregularities.

Note: Type 1a and 1b Horizontal Torsional Irregularity occur when displaced in the X-direction. Therefore, the structural modeling must comply with ASCE7-05 §12.7.3

Model

The model was loaded with the story forces determined in Lateral Loads – Earthquake section. Forces were modeled in the N/S direction and E/W direction per ASCE7-05 §12.5.2 and the design considerations mentioned above. The forces were applied at the center of mass with an eccentricity of 5%.

Period of Vibration		
Type	Motion Type	Period
Mode 1 (T1)	Torsion	2.06 s
Mode 2 (T2)	X	1.75 s
Mode 3 (T3)	Y	1.40 s

Table 25: ETABS Modal output for the first (3) degrees of freedom

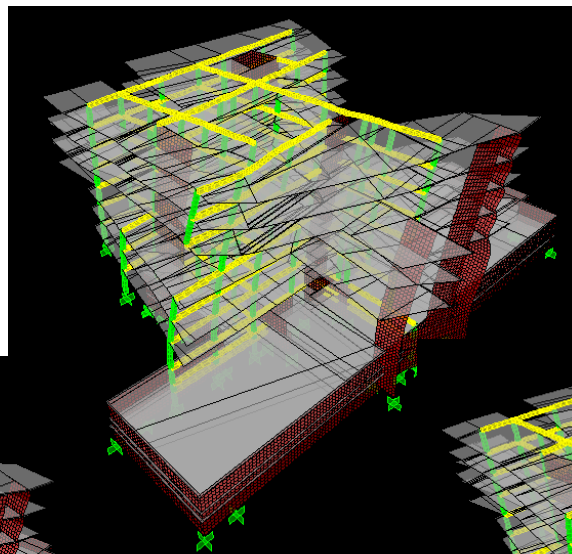
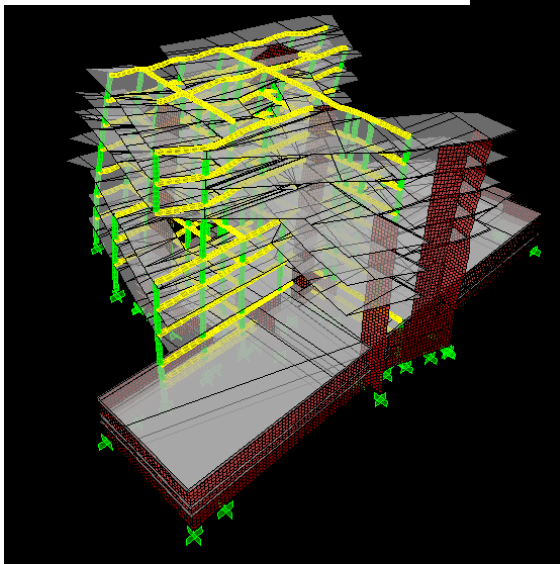
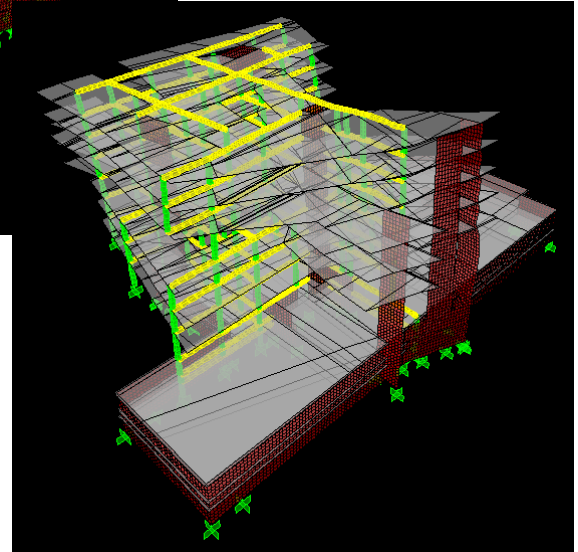
Figure 29: $T_x = 1.40$ sFigure 30: $T_z = 2.06$ sFigure 31: $T_y = 1.75$ s

Relative Stiffness

When the lateral system is loaded with the earthquake loads, the forces are dissipated through the frames. The 'stiffer' the element is (for this model, the concrete moment frames and shear walls) the more load that element resists; strength follows stiffness. As this system is modeled, the loads are applied to the center of mass of each rigid diaphragm. Since the diaphragm is rigid, all elements at the connection of the diaphragm move together. Once the loads are in the diaphragm they transfer to the lateral resisting elements. From these elements they travel to the foundation (modeled as a fix base), producing a base shear and overturning moment.

The USB has 7 shear walls and 6 moment frames that resist lateral load. When loaded in the East-West direction, the lateral system utilizes 4 shear walls and 3 moment frames to resist load, while the North-South Direction has 3 shear walls and 3 moment frames. The tables below show a percent relative stiffness of each resisting frame for each floor in both the North-South and East-West directions. **Red** indicates a frame at that particular level having a larger relative stiffness and the **blue** represents having a smaller relative stiffness. Note: All levels below 3 occur below grade and were neglected in these calculations.

Relative Stiffness							
N-S Force							
Level	CMF GO	CMF GI	CMF GC	CMF GO	SW GX	SW GD	SW GG
9	9%	46%	19%	13%	0%	7%	12%
8	3%	19%	10%	12%	6%	14%	36%
7	0%	13%	6%	13%	7%	18%	41%
6	0%	10%	5%	15%	6%	19%	45%
5	7%	9%	3%	11%	9%	21%	38%
4	4%	7%	3%	14%	8%	22%	42%
3	19%	3%	2%	23%	8%	25%	35%

N-S Force						
Level	CMF G9	CMF G16	CMF G18	SW G7	SW 12	G20
9	26%	22%	0%	4%	0%	52%
8	10%	11%	0%	23%	0%	54%
7	7%	8%	0%	23%	7%	54%
6	6%	6%	0%	27%	4%	57%
5	5%	4%	3%	23%	8%	49%
4	4%	3%	2%	26%	8%	55%
3	2%	2%	1%	28%	9%	51%

Table 26 - Relative stiffness of each lateral resisting element at each floor. Red shows larger relative stiffness and blue shows lower relative stiffness.

Rigidity and Torsion

As previously mentioned, the earthquake loads were applied to the center of mass at each level. That center of mass changes every floor due to its geometry. During the schematic layout of the lateral system, it was advantageous to layout the system as symmetrical as possible to help minimize the eccentricity between the center of rigidity and the center of mass. Due to the geometric irregularity, an eccentricity occurs on every floor. This eccentricity produces torsion about the vertical axis. Table () displays the location of the Center of Mass (COM) and Center of Rigidity (COR).

Center of Mass and Center of Rigidity				
Story	Center of Mass		Center of Rigidity	
	X	Y	X	Y
Roof	105.2	107.6	112.7	120.3
9	106.1	107.9	112.4	119.0
8	103.3	105.3	112.9	117.5
7	110.4	108.3	113.5	115.4
6	107.5	103.4	114.2	113.2
5	108.5	109.3	115.2	114.2
4	109.9	107.8	116.2	117.7
3	137.8	62.1	149.7	77.3
2'	137.9	63.1	146.0	79.0
2	137.8	63.1	144.0	80.1

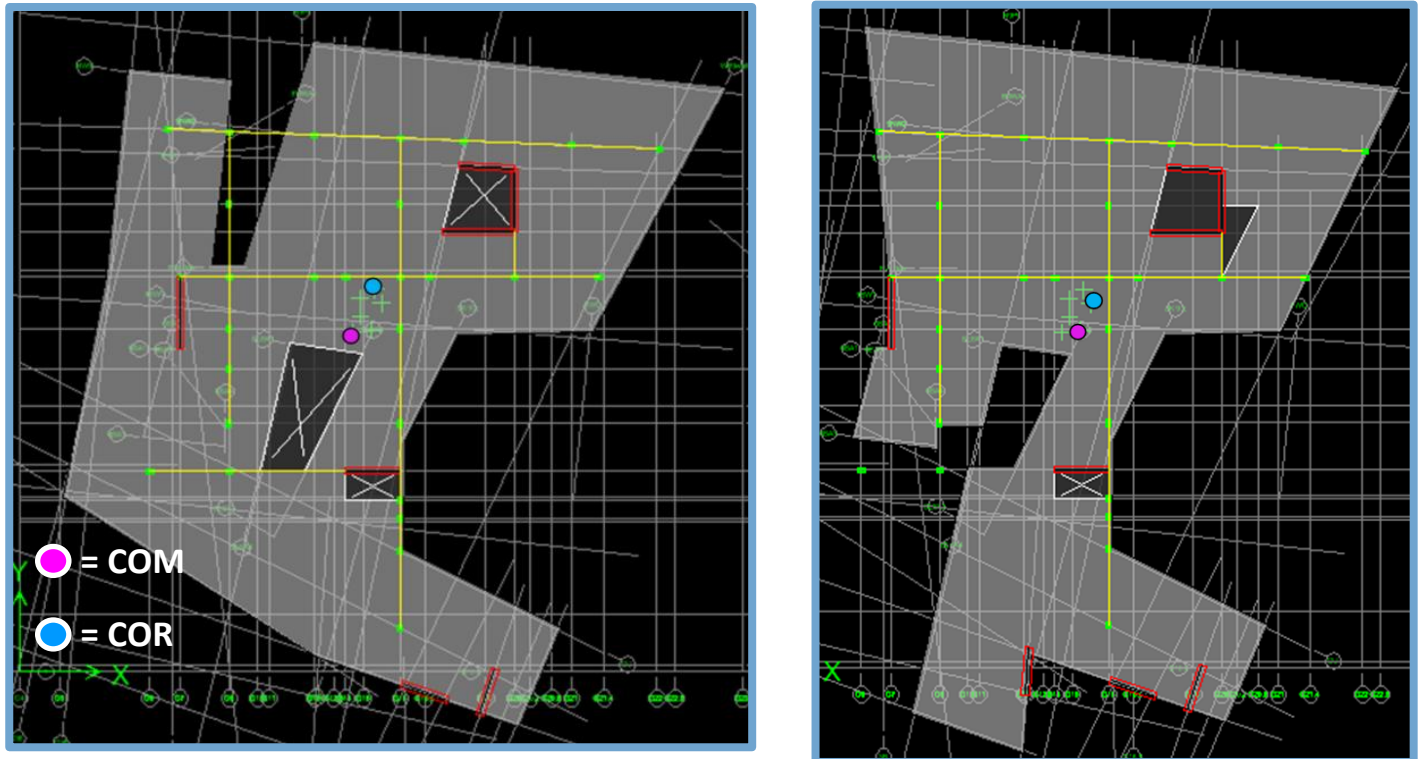

Figure 32 -Examples- plans Roof and 7 with indication of COM and COR.

Story Drift and Displacement

Overall displacement and drift are design considerations that are very important in evaluating the overall design of the structure. It is a serviceability concern that needs to be considered what the structure is applied with lateral loads. ASCE7-05 §12.8.6 *Story Drift Determination*, is an important design procedure when analyzing the story drift. It states the deflections at any level of the center of mass shall be multiplied by the deflection amplification factor and divided by the importance factor/

$$\delta_x = \frac{C_d \delta_{xe}}{I} \quad \text{ASCE7-05 Eq. 12.8-15}$$

The amplification factor is dependent on the seismic resisting system found in ASCE7-05 Tabel 12.1-1. The calcalated drift values must comply to the allowable story drift, Δa . Per ASCE7-05 Table 12.12-1 the allowable story drift for Occupancy Category II is as follows:

$$\Delta a = 0.015h_{sx}$$

Tables 28 and 29 display the displacements and story drifts for all the floors that are loaded with lateral loads.

Displacement				
Story	X-Direction		Y-Direction	
	δX	δY	δX	δY
ROOF	0.21708	-0.00936	-0.01584	0.259875
LEVEL9	0.18072	-0.00756	-0.0126	0.1386
LEVEL8	0.14364	-0.0054	-0.01044	0.11196
LEVEL7	0.108	-0.00432	-0.00684	0.08316
LEVEL6	0.07344	-0.00252	-0.00504	0.05832
LEVEL5	0.04392	-0.00108	-0.00216	0.03564
LEVEL4	0.0198	-0.00036	-0.00072	0.01692

Table 27 : Center of Mass displacement

Story Drift									
Story	Δa	X-Direction				Y-Direction			
		δX		δY		δX		δY	
Roof	0.195	0.002912	OK	0.000302	OK	0.0009828	OK	0.0026568	OK
9	0.195	0.002941	OK	0.000313	OK	0.0009756	OK	0.0009756	OK
8	0.195	0.002873	OK	0.000281	OK	0.0010008	OK	0.0010008	OK
7	0.195	0.002718	OK	0.000274	OK	0.000918	OK	0.0022932	OK
6	0.195	0.00243	OK	0.000907	OK	0.0009396	OK	0.000602	OK
5	0.195	0.004646	OK	0.000572	OK	0.000918	OK	0.0017856	OK
4	0.255	0.00234	OK	0.000572	OK	0.000882	OK	0.0011844	OK

Table 28 : Story drift

Shear Wall Design

Process

For this report, two shear walls were designed by hand calculations; hand calculations can be found in Appendix C. Section cuts were made under the controlling earthquake loads to determine the shear at each level. This shear multiplied by the story height would accumulate that shear walls moment diagram.

The two shear walls that are the focus of presentation are SW GG (X-Dir) and G7 (Y-Dir). The maximum shear, moment, and axial load were used to design the reinforcement for that particular loading. Once the flexural reinforcement steel was determined, section properties were entered into spColumn to check with the walls interaction diagram (Appendix C). The following tables and figures display the design of these two shear walls.

SW G7 Properties @ Level 3			
f'c=	8000	psi	fy= 60000 psi
Vu=	157.5	k	lw= 180 in
Mu=	9641.7	ft-k	d= 144 in
Pu =	1704.7	k	h= 12 in

Maximum Permitted Shear			
Vc,Max	1159.2	OK!	
Vc	510.5		
	145	Controls	
0.5φVc	54.375	< 157.5	Need Shear Reinforcement

Horizontal Reinforcement			
Try (2) #4's	Av/s	0.0075	
	use s=	12	
	ρ	0.00278	>.0025 OK!
Vertical Reinforcement			
Try (2) #4's	ρmin	0.00284	
	s	11.7	
	use s=	12	
	ρ	0.0028	>.0025 OK!

Flexural Reinforcement			
As,min	5.8	in2	
As	17.78	in2	Try (14) #10's
As,max	54.6	in2	
es=	0.01848		>.00207 OK!
			>.005 φ= 0.9
φMn	10,997	ft-k	> 9641.7 OK!

(14) #10s @ Ea. End

Horizontal Reinf.	(2) #4 @ 12'
Vertical Reinf.	(2) #4 @ 12'

Tables 29- Design calculations of SW G7

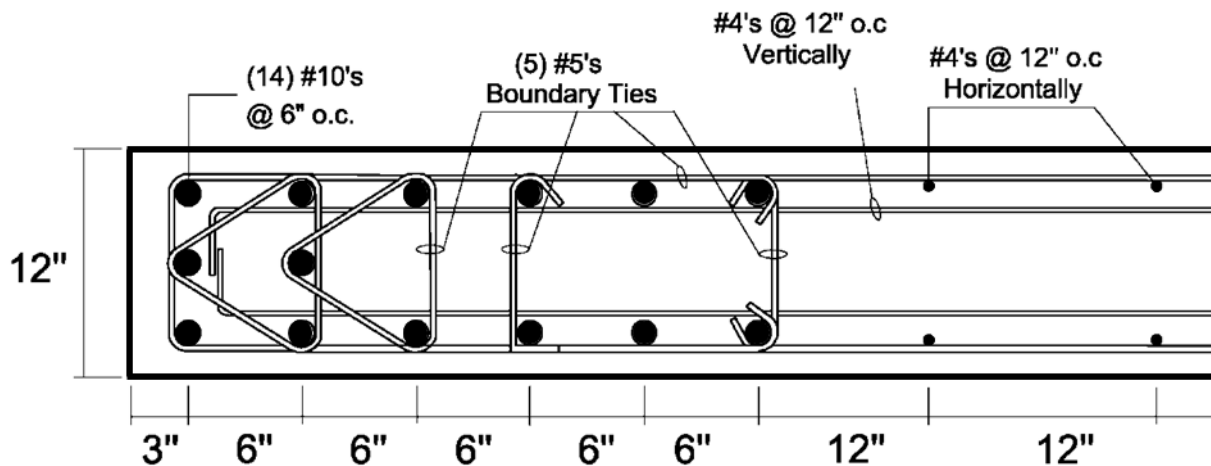

Figure 33: Designed flexural section of SW G7

SW GG Properties @ Level 3			
f'_c =	8000	psi	f_y = 60000 psi
V_u =	198	k	l_w = 240 in
M_u =	15000	ft-k	d = 196 in
P_u =	960	k	h = 12 in

Maximum Permitted Shear			
$V_{c,Max}$	1545.2	OK!	
V_c	680		
	202	Controls	
$0.5\phi V_c$	54.375	< 157.5	Need Shear Reinforcement

Flexural Reinforcement			
$A_{s,min}$	10.3	in ²	
A_s	17.78	in ²	Try (14) #10's
$A_{s,max}$	72.7	in ²	
e_s =	0.0261	>.00207	OK!
		>.005	$\phi = 0.9$
ϕM_n	15,158	ft-k	> 15,000 OK!

Horizontal Reinforcement			
Try (2) #4's	A_v/s	0.0054	
	use s=	12	
	ρ	0.00278	>.0025 OK!
Vertical Reinforcement			
Try (2) #4's	ρ_{min}	0.00273	
	s	12.2	
	use s=	12	
	ρ	0.0028	>.0025 OK!

Horizontal Reinf.	(2) #4 @ 12'
Vertical Reinf.	(2) #4 @ 12'

(14) #10s @ Ea. End

Table 30 - Design calculations of SW GG

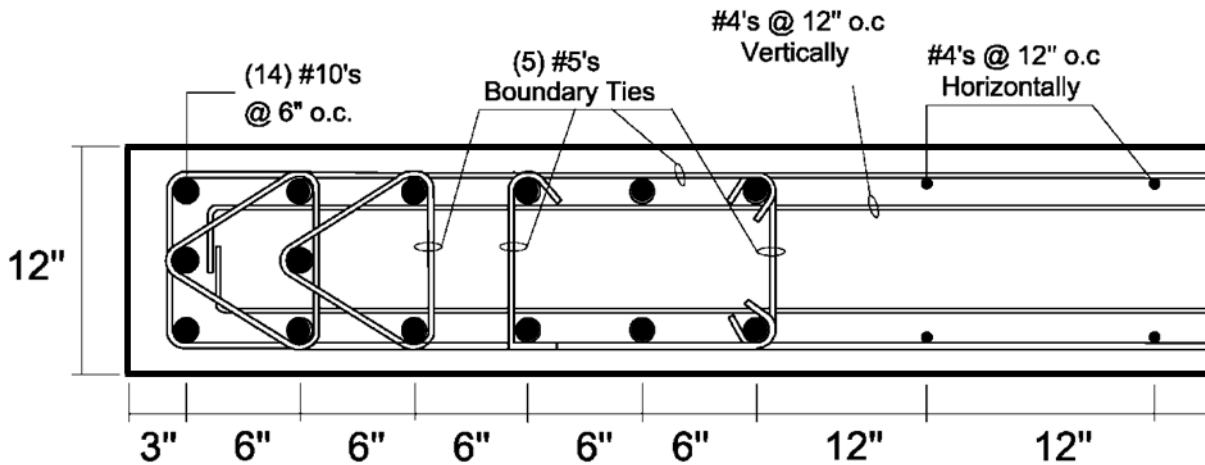
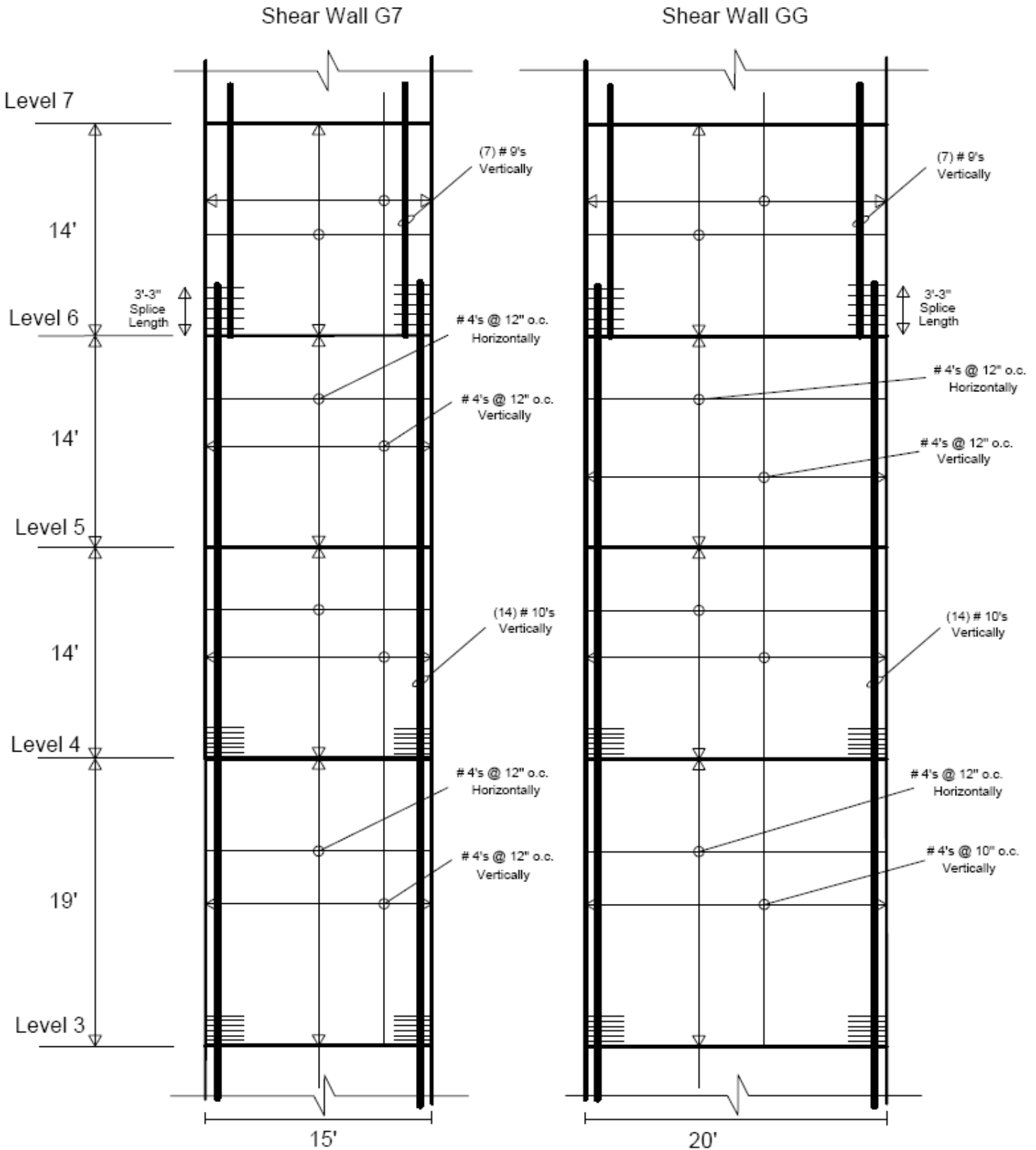

Figure 34 - Designed flexural section of SW

Both designs were conducted about level 3. As the shear wall gets higher, the lower the design values of V_u , M_u , and P_u get; changing the amount of needed reinforcement per the sections at higher elevations. The following image shows this change in the same two shear walls.

In addition, spColumn interaction diagrams can be found in Appendix C.

Figure 35 - Elevation of designed SW's G7 and GG



Moment Frame Column Design

Process

The design process for columns in moment frames follow a similar procedure as the shear walls. In ETABS, section cuts were made at each frame to determine the shear that column sees. EXCEL was used to organize the forces that each frame and column see in each direction. Once again, the shear found in ETABS at each floor was multiplied by the story height to determine the accumulative moment that the column will see.

Hand calculations were performed for 2 different moment frame columns at level 3 and can be found in Appendix D. They include Column G7-GI, and GC-G9. The design was performed using interaction diagram aids found in Appendix A of Reinforced Concrete Mechanics (Wright and MacGregor). spColumn was then used to check the design sections. Other columns of interest utilized spColumn's 'Design Section' feature, which yielded reasonable and similar results. The Table 30 displays a summary of the design.

Column G1/G7 @ Level 3					
Pu	926 k				
Mu	306 ft-k	$\rho =$	0.025	0.029	Fig 11a
Vu	3.3 k	$\rho =$	0.03		Fig 11b
f'c	6000 psi	As, req	12.6	ln2	
fy	60000 psi	As,min	1.67	ln2	
h	18 in	ρ_{max}	0.024		
b	24 in	As,max	10.23	ln2	
e	3.969122 in	As=	6.32	Ok	Use (8) # 8s
e/h	0.220507				
γ	0.722222			Shear	
Pu/bh	2.14	Vu=	3.26		
Mu/bh ²	0.35	Vc=	131.65 Ok		

Table 31- Design calculations for shear

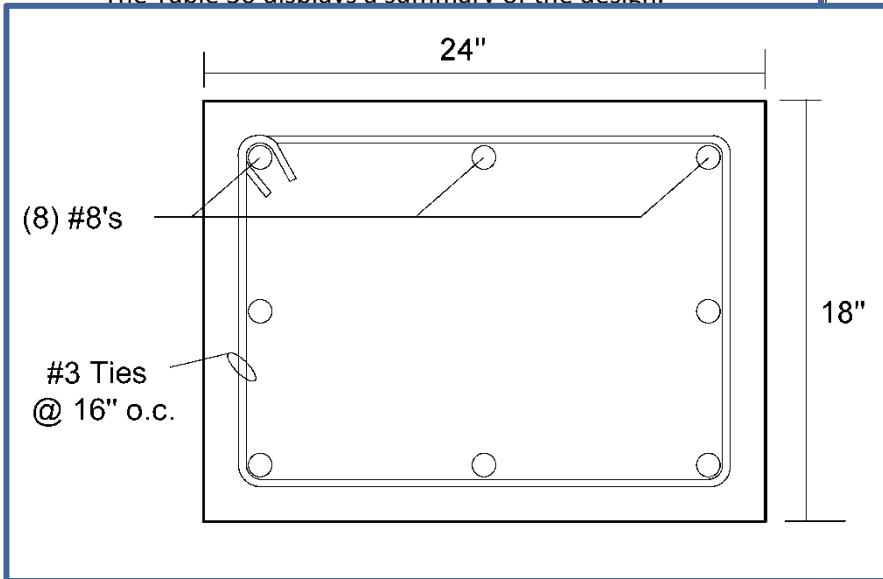

Figure 36: Column G1/G1 Section

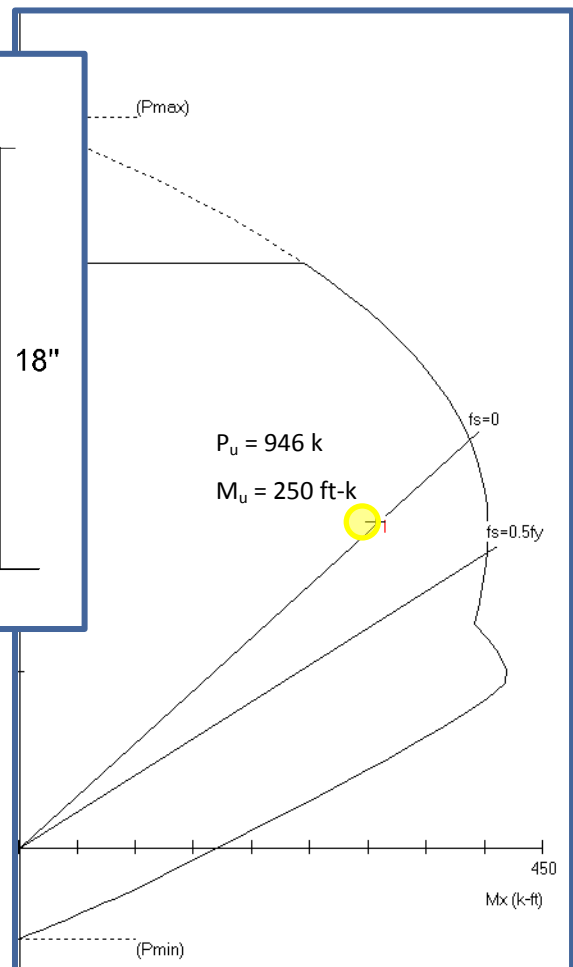

Figure 37: spColumn interaction design output

Moment Frame Beam Design

The design of the beam in the moment frame is very important, as the connection and uniformity of beam-column joints are vital to the moment frames effectiveness. The beam sees loading generated from gravity loads, as well as lateral loads. Moments are generated from the gravity loads that have been determined by moment coefficients. In the event of the earthquake, lateral loads will also induce moments upon these members. It is important to consider the movement from lateral loads in both directions. These moments are additive and the worst case scenario of combined moments will be what control the design of each section.

$$1.2D + 1.0E + L + 0.2S \quad (\text{ASCE7-05 } \S 2.3.2)$$

ACI 318-08 was used to assist in the design of these beams. Commentary R21.2 states that 'Ordinary Moment Frames' should be used in Seismic Design Category B, which this project is. Only two requirements for ordinary moment frames are given per Code and they are as follows:

ACI318-08 §21.2.2 – Beams should have at least two of the longitudinal bars continuous along both the top and bottom faces. Bars shall be developed at the face of the support.

ACI318-08 §21.2.3 – Columns having clear height less than or equal to five times the dimension c_i shall be designed for shear in accordance with §21.3.3 (clear height = $144'' < 5 \times c_1 = 120''$) Therefore, **does not apply**.

Image 38 displays the continuous beam that was designed and Table 32 shows the calculations made to detail the reinforcement.

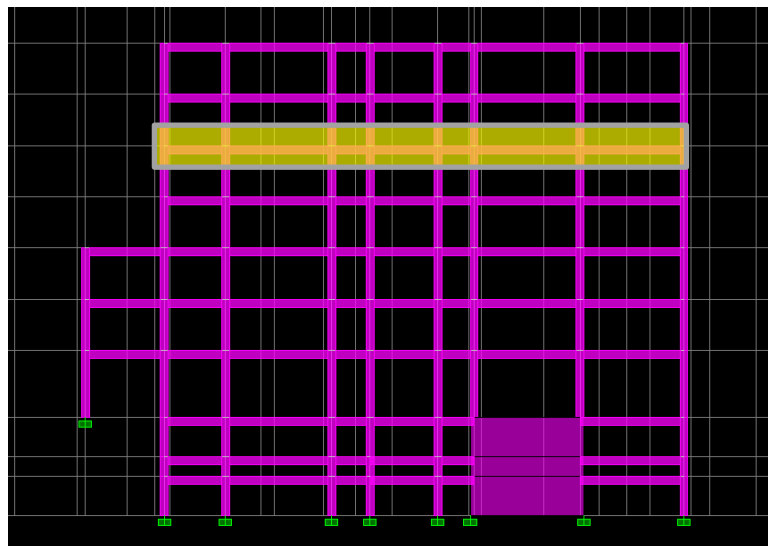

Figure 38 -Elevation of moment frame GO with highlight of level 8 beam to be designed

Moment Frame GI @ Level 8											
	1	2	3	4	5	6	7				
I_n (ft)	14.5	25	7.78	15.21	7.25	24.89	24.42				
Trib Width (ft)	20	20	20	20	20	20	20				
w_u gravity (kif)	5.43	5.43	5.43	5.43	5.43	5.43	5.43				
Flexural Design											
Mom. Coeff.	-0.042	0.063	-0.100	-0.091	0.063	-0.091	-0.091	0.063	-0.091	0.063	-0.091
M_u (' k)	-47.569	71.354	-114.17	-308.52	-29.879	71.354	-114.2	71.354	-114.2	-25.947	71.354
M_{u,eq} (' k) (Right Sway)	49.8	0	-48.12	35.84	0	-41.3	53.6	0	-53.8	42.7	0
M_{u,eq} (' k) (Left Sway)	-49.8	0	48.12	-35.84	0	41.3	-53.6	0	53.8	-42.7	0
M_{u1} total (' k)	-97.369	71.354	-162.29	-344.36	71.354	-344.22	-73.279	71.354	-168	-68.647	71.354
A_{s,req} (in2)	1.1592	0.8494	1.932	4.0996	0.8494	4.0979	0.8724	0.8494	1.9976	0.8494	2
A_{s,min} (in2)	1.95										
D_{max}	0.0273										
A_{s,max} (in2)	10.33										
A_{s,prov.} (in2)	(3) # 8	(3) # 8	(3) # 8	(3) # 8	(3) # 8	(3) # 8	(3) # 8	(3) # 8	(3) # 8	(3) # 8	(3) # 8
a (in)	2.37	2.37	2.37	2.37	2.37	2.37	2.37	2.37	2.37	2.37	2.37
c (in)	1.549	1.549	1.549	1.549	1.549	1.549	1.549	1.549	1.549	1.549	1.549
e_g	2.0654	2.0654	2.0654	2.0654	2.0654	2.0654	2.0654	2.0654	2.0654	2.0654	2.0654
φ	0.0275	0.0275	0.0275	0.0275	0.0275	0.0275	0.0275	0.0275	0.0275	0.0275	0.0275
Steel yield?	YES	YES	YES	YES	YES	YES	YES	YES	YES	YES	YES
φM_n (' k)	215.7	215.7	215.7	215.7	215.7	215.7	215.7	215.7	215.7	215.7	215.7
OK?	OK	OK	OK	OK	OK	OK	OK	OK	OK	OK	OK
Shear											
V_u/2 (k)	29.3										
V_u/φ (k)	52.49	52.49	90.5	28.164	55.06	28.164	55.06	26.245	90.102	26.245	90.102
Stirrups Needed?	YES	YES	YES	YES	YES	YES	YES	YES	YES	YES	YES
V_e	-6.0695	-6.0695	31.94	-30.396	-3.4993	-30.396	-3.4993	26.245	-32.315	26.245	31.542
d/2	10.5	10.5	10.5	10.5	10.5	10.5	10.5	10.5	10.5	10.5	10.5
A_{v,min} (in2)	0.174										
A_{v,prov} (in2)	(2) Legs #2	(2) Legs #2	(2) Legs #2	(2) Legs #2	(2) Legs #2	(2) Legs #2	(2) Legs #2	(2) Legs #2	(2) Legs #2	(2) Legs #2	(2) Legs #2
x (in)	21	21	141.17	21	21	21	21	43.5	21	149.34	146.52
x (ft)	1.75	1.75	11.764	1.75	1.75	1.75	1.75	3.625	1.75	12.445	12.21

Table 32- Design calculations for moment frame beam

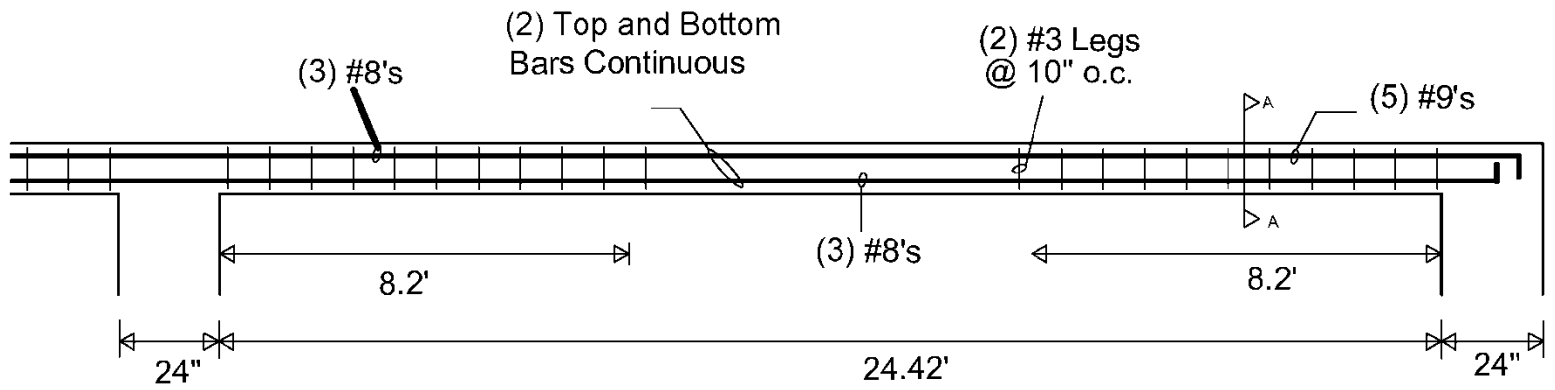

Figure 39 –Section of the exterior span on level 8

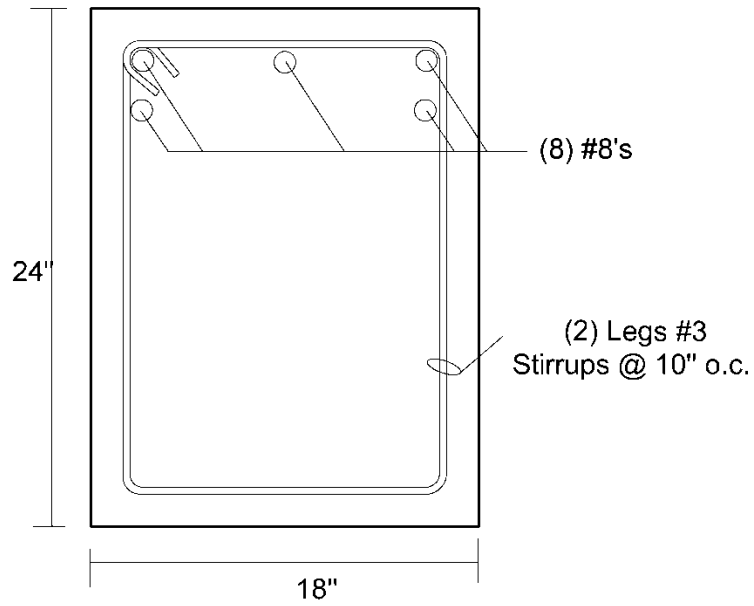

Figure 40 –Section AA

Mechanical Breadth Study

The façade of the USB is a very unique system in that it uses materials that are custom to the architecture and provide a visually intriguing appearance. The building façade is a built up system that is clad with 2' x 2' zinc panels and large windows with aluminum trimming. Each window for every room is placed in a different location from the adjacent one, presenting an interesting feel Figure41. With consideration of the repetition of these windows, it seemed reasonable to research the heat gain through these window systems. The current glass of this system is Viracon VE1-2M Low-E glass. Table 33 displays the specifications for this material.



Figure 41- West elevation showing the use of windows

Viracon VE1-2M Specs			
Transmittance		Reflectance	
Visible	70%	Visible Out	11%
Solar	33%	Visible In	12%
UV	10%	Solar	31%
U Value: 0.29			
Shading Coefficient: 0.44			
SHGC: 0.38			

Table 33 – Existing glazing specifications

The intent of this study is to explore options of improving the glazing of this window system to help reduce the cooling load of the spaces. A simple cost savings will help justify the investigation of this new application.

Process

Trane Trace 700 was used to model the spaces under investigation. For simplification purposes, only south facing walls were of interest. In addition, one room was modeled to represent the rest of the rooms. Results of this room were then multiplied by the total number of rooms that are south facing; 68 total.

Upon research of a viable alternative glazing, one was chosen with the following specifications. A full spec sheet can be found in Appendix ().

Viracon VE1-2M V175 Specs			
Transmittance		Reflectance	
Visible	39%	Visible Out	24%
Solar	18%	Visible In	30%
UV	4%	Solar	26%
U Value: 0.25			
Shading Coefficient: 0.26			
SHGC: 0.23			

Table 34 – Proposed glazing specifications

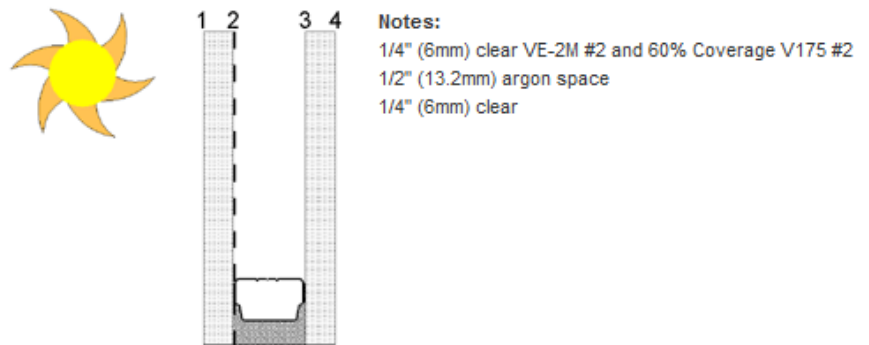

Figure 42- Proposed glazing section properties

The following tables display a summary of the analysis conducted the existing and proposed systems.

Heating Loads			
South Façade	Existing	Proposed	Difference
U-Value (Btu/ft ² ·°F·hr)	0.1505	0.1385	
Area (ft ²)	177	177	
Annual Heat Loss per room (Btu)	4,623,360	4,255,034	
Annual Heat Loss per room (kWh)	1,355	1,247	108
Offices	68	68	
Annual Heat Loss (Btu)	314,388,447	289,342,319	25,046,128
Annual Heat Loss (kWh)	92,138	84,798	7,340

Cooling Loads			
South Façade	Existing	Proposed	Difference
U-Value (Btu/ft ² ·°F·hr)	0.1505	0.1385	
Area (ft ²)	245,295	245,295	
Annual Heat Loss per room (Btu)	71,419,132	65,729,442	
Annual Heat Gain per room (kWh)	20,931	19,263	1,667
Offices	68.00	68	
Annual Heat Gain (Btu)	4,856,500,962	4,469,602,065	386,898,898
Annual Heat Gain (kWh)	1,423,300	1,309,911	113,389

Cooling Total (Btu/h)		
Envelope	Internal Loads	Total
4075	1384	5459

Heating Total (Btu/h)		
Envelope	Internal Loads	Total
-2288	0	2288

Tables 35-38 – Combined cooling and heating loads

Cooling Load Annual Cost			
South Façade	Existing	Proposed	Difference
Annual Heat Gain per room (Btu)	10,559,889.6	17,411,534.4	
Annual Heat Gain per room (kWh)	3094.798146	5102.81702	-2008.01887
Rooms on East Side of Building	68	68	
Annual Heat Gain (Btu)	718072492.8	1183984339	-465911846
Annual Heat Gain (kWh)	210446.2739	346991.5574	-136545.283
		Total kWh Saved	-136545.283
		Price/kwh	\$ 0.15
		Annual Savings	\$(20,754.88)

Heating Loads Annual Cost			
South Façade	Existing	Proposed	Difference
Annual Heat Loss per room (Btu)	447096552	432881952	
Annual Heat Loss per room (kWh)	131031.065	126865.1769	4165.888034
Rooms on East Side of Building	68	68	
Annual Heat Loss (Btu)	30402565536	29435972736	966592800
Annual Heat Loss (kWh)	8910112.418	8626832.031	283280.3863
		Total kWh Saved	283280.3863
		Price/kwh	\$ 0.15
		Annual Savings	\$ 43,058.62

Additional Material Cost	(\$ 6,487.2)
Annual Savings	\$ 22,939
Total Annual Savings	\$16,451

Tables 39-41 – Summary of Annual cost savings

Conclusions

This alternative glazing system seems to be a viable one that would initially cost more but over its life cycle would more than pay itself off. In addition, analysis of east, west, and north facades would most likely prove to benefit from this new system, incurring additional savings.

Construction Management Breadth

As stated in the problem state, the efficiency of the construction was the reason to redesign the structure to concrete. Complications with the erection and connections of steel delayed the schedule by nearly 2 months. This inherently caused an increase in project costs. The purpose of this construction management investigation was to estimate the total cost of the concrete structure as well as a detailed schedule. As previously stated, similar to how only levels 4-Roof were redesigned because the bottom floors were already concrete, only these floors will be analyzed in this investigation. Once these were completed they would be compared to the existing data. For the purpose of even comparison, both the estimate and schedule of the existing schedule were made under the same assumptions and techniques as the new concrete structure; allowing for a fair comparison.

Cost Analysis

The process of estimating and cost analysis is a project is very detailed and has been simplified to achieve reasonable results. For the existing structural system estimate simplifying assumptions were made and are as follows:

1. All costs were time adjusted to represent the cost of the project if it were to be built as concrete instead of steel (June 2009).
2. RS Means 2010 was used to compile all material, labor, equipment, and overhead/profit values.
3. Pricing was adjusted to the appropriate location.
4. Take off values only include steel framing members (columns, beams, bracing), shear studs, metal decking, concrete topping, finishing, and fireproofing.

The following were assumptions used in estimating the new concrete structural system:

1. All costs were time adjusted to represent the cost of the project if it were to be built as concrete instead of steel (June 2009).
2. RS Means 2010 was used to compile all material, labor, equipment, and overhead/profit values.
3. Pricing was adjusted to the appropriate location.
4. Take off values only include type of concrete (4000psi, 8000psi, etc.), placing of concrete, reinforcement bars, formwork and finishing.

The following tables show a summary of the comparison of the two estimates. A more detailed cost analysis can be found in Appendix E.

Total Cost Comparison			
Type	Square Footage	System Cost	\$/S.F
Concrete (New Design)	146,778 ft ²	\$ 5,281,312	\$ 35.98
Steel (Existing Design)	146,778 ft ²	\$ 4,486,006	\$ 30.56
Cost Difference		(+ \$ 795,306)	
Additional Cost %		(+) 17.7%	

Tables 42 – Summary of cost comparison between the existing and new design

Schedule Impact

The scheduling of the concrete structure is vital to understand the comparison between the existing structure and the proposed new one. RS Means was used to determine what specific crews could accomplish in a day and how long it would take to complete the task. For simplicity, the general layout of the schedule follows a two phase sequence per floor. It is the intent that overlapping occurs, in that while one phase is in progress, the second phase on the floor begins.

As previously stated, the complication of erection and detailing of the steel structure delayed the project by two months. The concrete structure is thought to have a more predictable and efficient flow. In addition, the construction of the concrete would occur during the spring/summer, eliminating the issues and delays associated with the winter months. Figure () gives an abbreviated schedule for the floors. A more detailed schedule can be found in Appendix E.

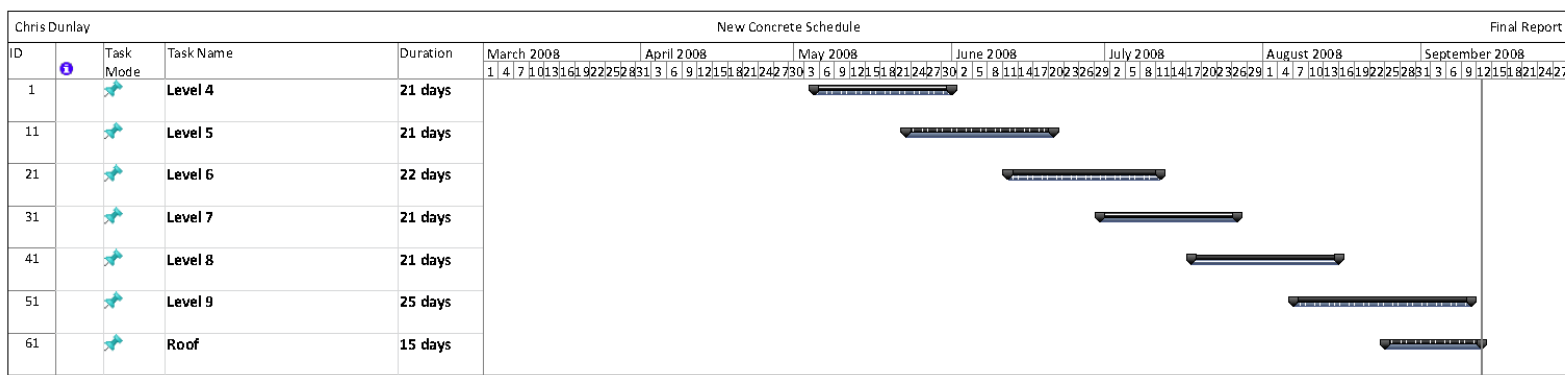

Figure 43 – Schedule of the construction per floor

Also, a Google Sketchup model has been made to help understand the construction sequence more clearly. Sketchup's Section Cuts and Animation features were used to generate a film of how the construction sequence would work. (Available upon request)

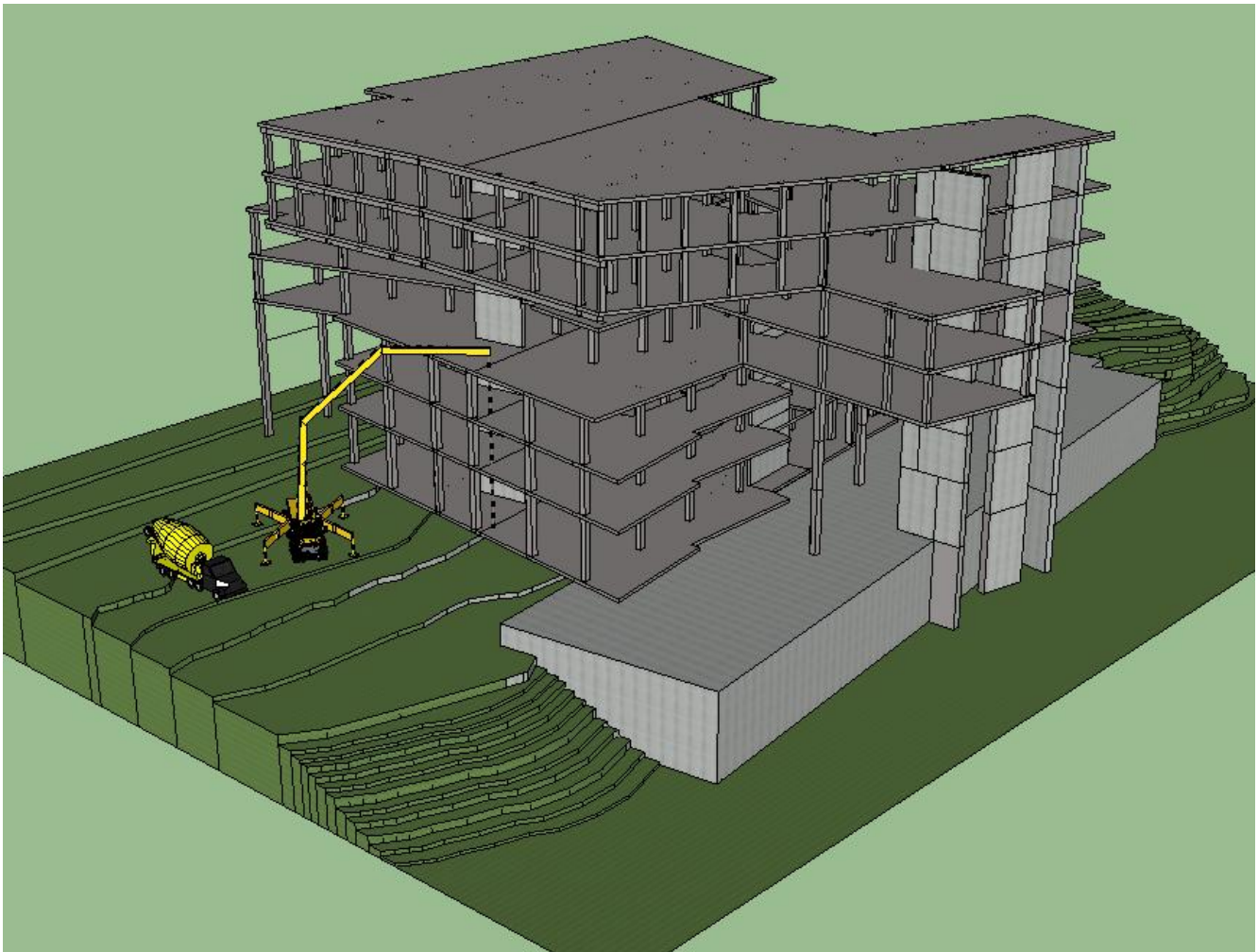

Figure 43 – Google Sketchup Model

Conclusions

The original design and construction of The University Sciences Building encountered issues that greatly contributed to an additional 2 month of the construction schedule during steel erection. Consequently, this also incurred unforeseen costs. The main goal of this thesis was to design a concrete structure that meet all strength and serviceability requirements that also provides a more efficient schedule and a cost that is easily manageable through the efficiency of construction.

To help facilitate an efficient construction schedule it was intended to design a complete flat plate floor system for is uniformity with the use of formwork. As the design of the structure progressed, the need for beams in specific areas (moment frames and edge beams) slightly disrupted that continuous use of formwork. A two way flat plate floor system was design to be 12" thick at 6000 psi. The slab is mild-heavily reinforced to help resist moments and shear in the large spans. Equivalent frame methods were used to achieve a preliminary design the system and RAM concept was utilized to produce a final design.

In order to resist gravity loads on the cantilevers on floors 8-Roof, a concrete truss was designed. It was determined that deflections would control the design of this system. An iterative process was performed to achieve the most efficient design.

Due to the switch of material from a steel superstructure to concrete inherently increased the overall weight of the building. Where lateral wind loads controlled the design of the existing structure, earthquake would control for the redesign. Through the assistance of ACI318-08 and ASCE7-05, at shear wall-moment frame interactive system was adequately design to resist all loads in the event of an earthquake and during strong wind loading. ETABS was used to analyze the structure and produce output design values for the design of lateral resisting members.

As the reason for this redesign was primarily due to the delay and incurred costs to the steel superstructure, a construction management investigation was performed to search for an efficient sequencing of construction that would help eliminate the issues that were encountered. In addition, the total cost of a concrete structure is very different that the cost of a steel structure. Therefore a cost estimated for both of these systems was conducted to determine the actual viability of constructing this redesign. Google Sketchup was used to construct a model that helps visualize the process of construction. It was intended that this 3D, visually pleasing model would help all parties involved in the construction to have a better understanding of the process.

Finally, a mechanical investigation was performed to see how effective changing the glazing on all south facing rooms would help reduce the cooling load needed to resist the heat gain. Trane Trace 700 was used to model these spaces and produce output for both the existing and proposed conditions. The change of glazing to more favorable design values produce pay back figures that would be desirable to any owner.

Upon the completion of this report, it has been determined that the redesign would be a viable solution to the problem at hand. Unforeseen obstacles will always present themselves but efficiency of this concrete construction outweighs that of a steel structure.

References

- Building Code Requirements for Structural Concrete (ACI 318-08) and Commentary*. Farmington Hills, MI: American Concrete Institute, 2008. Print.
- Minimum Design Loads for Buildings and Other Structures (ASCE7-05) and Commentary*. American Society of Civil Engineers, 2005. Print.
- Leet, Kenneth, and Chia-Ming Uang. *Fundamentals of Structural Analysis*. Boston: McGraw-Hill, 2002. Print.
- Wight, James K., F. E. Richart, James G. MacGregor, and James G. MacGregor. *Reinforced Concrete: Mechanics and Design*. Upper Saddle River, NJ: PEARSON PRENTICE HALL, 2012. Print.
- Nilson, Srthur H., Darwin, David., Dolan, Charles W., *Design of Concrete Structures*. Boston: McGraw-Hill, 2010. Print.

Appendix A: Gravity Calculations

Appendix B: Truss Design

Appendix C: Shear Wall Design

Appendix D: Concrete Moment Frame Design

Appendix E: Detailed Schedule and Cost

Item	Size	Unit	Material	Labor	Equipment	Total	Total Incl. O&P	Location	Amount	Total O&P	Total Price
Steel Beam	W18x50	L.F.	\$ 60.50	\$ 4.05	\$ 1.92	\$ 66.47	\$ 75.50	Roof	4,050.00	\$269,203.50	\$ 305,775.00
Steel Beam	W18x50	L.F.	\$ 60.50	\$ 4.05	\$ 1.92	\$ 66.47	\$ 75.50	9	4,050.00	\$269,203.50	\$ 305,775.00
Steel Beam	W18x50	L.F.	\$ 60.50	\$ 4.05	\$ 1.92	\$ 66.47	\$ 75.50	8	4,050.00	\$269,203.50	\$ 305,775.00
Steel Beam	W21x50	L.F.	\$ 60.50	\$ 3.47	\$ 1.65	\$ 65.62	\$ 74.50	7	3,926.70	\$257,670.05	\$ 292,539.15
Steel Beam	W21x62	L.F.	\$ 75.00	\$ 3.57	\$ 1.69	\$ 80.26	\$ 90.50	6	5,444.00	\$436,935.44	\$ 492,682.00
Steel Beam	W21x68	L.F.	\$ 82.50	\$ 3.57	\$ 1.69	\$ 87.76	\$ 98.50	5	3,864.90	\$339,183.62	\$ 380,692.65
Steel Beam	W18x50	L.F.	\$ 60.50	\$ 4.05	\$ 1.92	\$ 66.47	\$ 75.50	4	4,050.00	\$269,203.50	\$ 305,775.00
Steel Column	W12x87	L.F.	\$ 105.00	\$ 3.99	\$ 2.51	\$ 111.50	\$ 126.00	4	1,205.00	\$134,357.50	\$ 151,830.00
Steel Column	W12x87	L.F.	\$ 105.00	\$ 3.99	\$ 2.51	\$ 111.50	\$ 126.00	5	1,292.00	\$144,058.00	\$ 162,792.00
Steel Column	W12x72	L.F.	\$ 87.00	\$ 3.99	\$ 2.51	\$ 93.50	\$ 106.00	6	910.00	\$ 85,085.00	\$ 96,460.00
Steel Column	W12x72	L.F.	\$ 87.00	\$ 3.99	\$ 2.51	\$ 93.50	\$ 106.00	7	812.00	\$ 75,922.00	\$ 86,072.00
Steel Column	W12x50	L.F.	\$ 65.50	\$ 3.41	\$ 2.14	\$ 66.05	\$ 74.50	8	550.00	\$ 36,327.50	\$ 40,975.00
Steel Column	W12x50	L.F.	\$ 65.50	\$ 3.41	\$ 2.14	\$ 66.05	\$ 74.50	9	550.00	\$ 36,327.50	\$ 40,975.00
Truss Column	W24x146	L.F.	\$ 177.00	\$ 3.52	\$ 1.67	\$ 182.19	\$ 202.00	8	280	\$ 51,013.20	\$ 56,560.00
Truss Column	W24x146	L.F.	\$ 177.00	\$ 3.52	\$ 1.67	\$ 182.19	\$ 202.00	9	280	\$ 51,013.20	\$ 56,560.00
Truss Beam	W18x106	L.F.	\$ 128.00	\$ 4.11	\$ 1.95	\$ 134.06	\$ 150.00	9	185.25	\$ 24,834.62	\$ 27,787.50
Truss Beam	W18x106	L.F.	\$ 128.00	\$ 4.11	\$ 1.95	\$ 134.06	\$ 150.00	9	280	\$ 37,536.80	\$ 42,000.00
Truss Beam	W30x325	L.F.						9	171	\$ -	\$ -
Truss Beam	W30x211	L.F.						9	171	\$ -	\$ -
Steel Deck	3" 18GA	S.F.	1.8	0.53	0.05	2.38	2.98	All Stories	146778	\$349,331.64	\$ 437,398.44
Roof Deck	3" 18GA	S.F.	1.92	0.51	0.05	2.38	2.89	Roof	23197	\$ 55,208.86	\$ 67,039.33
Concrete Topping	4000 PSI Conc.	C.Y.	103			103	113	All Stories	2718	\$279,965.44	\$ 307,146.56
Placing Concrete	6" pumped	C.Y.		14.15	11.75	35.25	48.5	All Stories	2718	\$ 95,813.42	\$ 131,828.39
Fireproofing	Deck	S.F.	0.53	0.53	0.06	0.94	1.16	All Stories	146778	\$137,971.32	\$ 170,262.48
Fireproofing	Columns	S.F.	1.13	1.19	0.19	2.51	3.25	All Stories	23,516.00	\$ 59,025.16	\$ 76,427.00
Fireproofing	Beams	S.F.	0.53	0.56	0.09	1.18	1.52	All Stories	90,728.55	\$107,059.69	\$ 137,907.40
Concrete Finish	Bull Float	S.F.	-	\$ 0.35	-	\$ 0.35	\$ 0.57	All Stories	146,778.00	\$ 51,372.30	\$ 83,663.46
Curb Edging	12" Channel	L.F.	\$ 28.00	\$ 7.40	-	\$ 35.40	\$ 43.50	All Stories	1,377.00	\$ 48,745.80	\$ 59,899.50
Existing Steel Structure											
\$ 4,486,006.15											

New Concrete Structure												
Concrete Slab	6000 psi	CY	124						124	All Stories	2718.11	\$ 337,045.78
Concrete SW CMF	8000 psi	C.Y.	203						203	All Stories	2718.11	\$ 551,776.56
Columns	6000 psi	C.Y.	124						124	All Stories	2718.11	\$ 337,045.78
Columns	4500 psi	C.Y.	106						106	All Stories	2718.11	\$ 288,119.78
Placing Concrete	Slab	C.Y.		19.8	9.95				29.75	All Stories	2718.11	\$ 80,863.81
Placing Concrete	GravityColumns	C.Y.		36	16.2				52.2	All Stories	325.00	\$ 16,965.00
Placing Concrete	M. F. Columns	C.Y.		30.75	13.575				44.325	All Stories	234.00	\$ 10,372.05
Placing Concrete	Shear Walls	C.Y.		20.5	7.25				27.75	All Stories	343.78	\$ 9,539.83
Placing Concrete	Beams	C.Y.		32.25	14.375				46.625	All Stories	407.33	\$ 18,991.92
Slab Rebar	Rebar	Tons	850	515					1365	All Stories	657.5	\$ 897,507.99
SW Rebar	Rebar	Tons	760	375					1135	All Stories	38.5	\$ 43,742.75
Rebar Col.	Rebar	Tons	800	650					1450	All Stories	274.7	\$ 398,377.35
Slab Formwork	3 use Flat Plate	SF	1.63	3.57					5.2	All Stories	146778	\$ 763,245.60
Grav. Col. Formwork	4 use 16x16	SFCA	0.67	5.35					6.02	3 to 6	12870	\$ 77,477.40
Grav. Col. Formwork	4 use 24x24	SFCA	0.74	5.3					6.04	7 to 9	10296	\$ 62,187.84
Mom. Col. Formwork	4 use 24x24	SFCA	0.74	5.3					6.04	All Stories	25740	\$ 155,469.60
Mom. Bm Formwork	4 use 12' Wide	SFCA	1.31	5.15					6.46	All Stories	24195.60	\$ 156,303.58
Shear Wall Formwork	16 4 use	SFCA	0.59	4.982					5.51	All Stories	6864.00	\$ 37,820.64
Concrete Finish	Bull Float	S.F.	-	0.35	-				0.35	All Stories	146,778.00	\$ 51,372.30
												\$ 5,281,312.41

Appendix F: Lateral Calculations

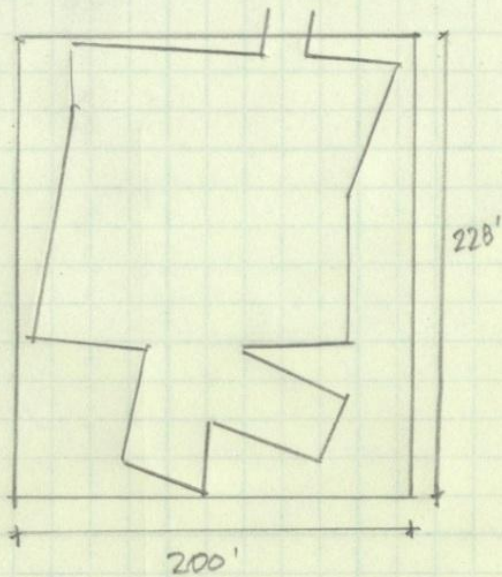

BUILDING 1

- BASE & LENGTH

- ↳ N-S → $L = 228'$ $B = 200'$

- ↳ E-W → $L = 200'$ $B = 228'$

- THIS BUILDING HAS THREE DIFF. HEIGHTS. THE LARGEST HEIGHT WILL BE TAKEN AS THE UNIFORM HEIGHT = $142'$

- METHOD 2 - ANALYTICAL PROCEDURE

- ↳ BASIC WIND SPEED, $V = 90$ MPH (FIG 6-1)
- ↳ WIND DIRECTIONALITY FACTOR, $K_d = 0.85$ (TABLE 6-1)
- ↳ OCCUPANCY CATEGORY = III (TABLE 1-1)
- ↳ IMPORTANCE FACTOR = 1.15 (TABLE 6-1) NON-HURRICANE
- ↳ EXPOSURE CATEGORY = B (§ 6.5.6.3)
- ↳ TOPOGRAPHIC FACTOR, $Z_{eT} = 1.0$ (§ 6.5.7) HOMOGENEOUS TOPO
- ↳ INTERNAL PRESSURE = ± 0.18 (FIG 6.5) ENCLOSED BLDG
- ↳ VELOCITY PRESSURE COEFFICIENT = $K_2 - K_h$
- ↳ VELOCITY PRESSURES

$$\left. \begin{aligned} \bullet q_e &= 0.00256 K_2 K_{zT} K_d V^2 I \\ \bullet q_h &= 0.00256 K_h K_{zT} K_d V^2 I \end{aligned} \right\} \text{SEE EXCEL}$$

↳ GUST FACTOR

$$\bullet T_a = C_t h_n^X = 0.02 (142)^{0.75} = 0.823 \text{ s}$$

$$\bullet f = 1/T_a = 1/0.823 = 1.21 > 1.0 \rightarrow G = 0.85$$

↳ CALCULATE ACTUAL GUST FACTOR

◦ NORTH-SOUTH

$$- \bar{z} = 0.6 (142) = 85.2' > 30' \text{ OK! } \checkmark$$

$$- C = 0.3$$

$$- l = 320 \text{ ft}$$

$$- \bar{z} = 1/3.0$$

$$- L_{\bar{z}} = l \left(\frac{\bar{z}}{33} \right)^{\bar{z}} = 320 \left(\frac{85.2}{33} \right)^{1/3} = 439$$

$$- I_{\bar{z}} = C \left(\frac{33}{\bar{z}} \right)^{1/6} = 0.3 \left(\frac{33}{85.2} \right)^{1/6} = 0.143$$

$$- Q = \sqrt{\frac{1}{1 + 0.63 \left(\frac{B+h}{L_{\bar{z}}} \right)^{0.63}}} = \sqrt{\frac{1}{1 + 0.63 \left(\frac{200+142}{439} \right)^{0.63}}} \\ = 0.806$$

$$- G = 0.925 \left[\frac{(1 + 1.7g_v I_{\bar{z}} Q)}{1 + 1.7g_v I_{\bar{z}}} \right] = 0.925 \left[\frac{1 + 1.7(3.4)(0.143)(0.806)}{1 + 1.7(3.4)(0.143)} \right] \\ = 0.844$$

◦ EAST-WEST

$$- Q = \sqrt{\frac{1}{1 + 0.63 \left(\frac{228+142}{439} \right)^{0.63}}} = 0.799$$

$$- G = 0.925 \left[\frac{1 + 1.7(3.4)(0.143)(0.799)}{1 + 1.7(3.4)(0.143)} \right]$$

$$= 0.840$$

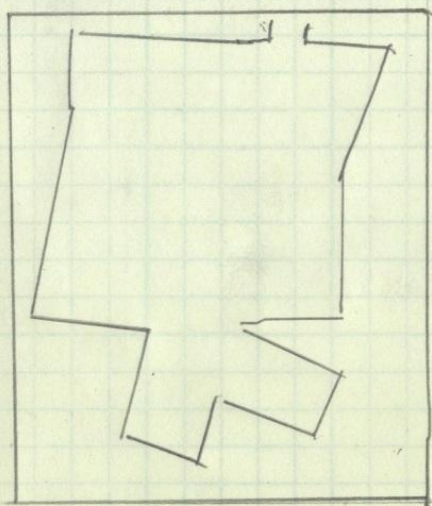

SITE CLASS - C (FROM GEOTECHNICAL REPORT)

OCCUPANCY CATEGORY - III (TABLE 1-1)

IMPORTANCE FACTOR - 1.25 (TABLE 11.5-1)

$S_s = 0.128$ (FROM USGS)

$S_1 = 0.06$

SITE COEFFICIENTS:

$F_a = 1.2$ (TABLE 11.4-1)

$F_v = 1.7$ (TABLE 11.4-2)

- SHORT SPECTRAL RESPONSE ACCEL - $S_{ms} = F_a S_s = (1.2)(0.128) = 0.1536$
- 1-SECOND SPECTRAL RESPONSE ACCEL - $S_{m1} = F_v S_1 = (1.7)(0.06) = 0.102$
- DESIGN SRA - $S_{DS} = \frac{2}{3} S_{ms} = (\frac{2}{3})(0.1536) = 0.1024$
- DESIGN SRA - $S_{D1} = \frac{2}{3} S_{m1} = (\frac{2}{3})(0.102) = 0.068$

↳ SEISMIC DESIGN CATEGORY (TABLE 11.6-1)

$S_{DS} = 0.1024$ w/ Occ. Cat = III

$S_{DS} < 0.167$ → CATEGORY A

- RESPONSE MODIFICATION COEFFICIENT, $R = 5$ (TABLE 12.2-1)

USE EQUIVALENT LATERAL FORCE ANALYSIS (

↳ APPROXIMATE PERIOD (TABLE 12.8-2)

$$\begin{aligned} \bullet T_a &= C_t h^n \rightarrow \text{STRUCTURE TYPE "ALL OTHER STRUCTURAL SYSTEMS"} \\ &= (0.02)(103)^{0.75} = 0.647 \end{aligned}$$

$$\bullet \text{FREQUENCY} \rightarrow f = 1/T_a = 1.55$$

↳ SEISMIC RESPONSE COEFFICIENT.

$$\bullet C_u = 1.7 \rightarrow (\text{TABLE 12.8-1 } S_{D1} \leq 0.1)$$

$$C_{s, \text{CALC}} = \frac{S_{DS}}{(R/I)} = \frac{0.1024}{(5/1.25)} = 0.0256$$

$$C_{s, \text{MAX}} = \begin{cases} \frac{S_{D1}}{T(R/I)} & ; \text{ FOR } T \leq T_L \\ \frac{T_L S_{D1}}{T^2 (R/I)} & ; \text{ FOR } T > T_L \end{cases}$$

($T_L = 12 \rightarrow T_{BL} 22-15$)
T =

↳ SEE CALC

• BASE SHEAR

$$V = C_s W ; W \text{ CAN BE FOUND IN EXCEL SHEET}$$

$$= (0.0256)(23,812 \text{ K}) = 609.6 \text{ K}$$

$$\% = 1 - \left(\frac{609.6 \text{ K}}{620.6 \text{ K}} \right) \times 100 = 1.77\% \text{ DIFFERENCE}$$

• SEE EXCEL SHEET FOR REMAINING CALCS
& BUILDING 2

Earthquake - N/S and E/W Directions									
Level	h_i (ft)	h (ft)	w (k)	$w \cdot h^k$	C_{vx}	f_i (k)	V_i (k)	M (ft-k)	
Roof	13	120	6104	18107029	0.229	135	0	16145	
9	13	107	7001	17148691	0.217	127	135	13634	
8	13	94	7586	14967055	0.189	111	262	10454	
7	13	81	6575	10117326	0.128	75	373	6089	
6	13	68	8469	9730206	0.123	72	448	4916	
5	13	55	4895	3946012	0.050	29	521	1613	
4	13	42	5100	2620574	0.033	19	550	818	
3	17	25	11552	2495841	0.032	19	569	464	
Base	25	0	0	0	0.000	0	588	0	
Σ			57282	79132735		588		54134	

Y Direction					
	Floor	Story Shear (k)	Story Force (k)	Percent Stiffness (%)	Relative Stiffness
Frame G9	Roof	0		0.0%	6.16%
	9	135	-35.6823	-26.4%	
	8	262	-26.1844	-10.0%	
	7	373	-27.2796	-7.3%	
	6	448	-26.9242	-6.0%	
	5	521	-27.6521	-5.3%	
	4	550	-23.1704	-4.2%	
Frame G18	Roof	0		0.0%	1.07%
	9	135	0	0.0%	
	8	262	0	0.0%	
	7	373	0	0.0%	
	6	448	0	0.0%	
	5	521	-15.9936	-3.1%	
	4	550	-9.4063	-1.7%	
Frame G16	Roof	0		0.0%	5.92%
	9	135	-29.9277	-22.2%	
	8	262	-29.2757	-11.2%	
	7	373	-30.664	-8.2%	
	6	448	-27.5012	-6.1%	
	5	521	-21.3899	-4.1%	
	4	550	-18.7926	-3.4%	
SW G7	Roof	0		0.0%	24.24%
	9	135	-5.0816	-3.8%	
	8	262	-61.3387	-23.4%	
	7	373	-85.2546	-22.9%	
	6	448	-120.8527	-27.0%	
	5	521	-120.6477	-23.2%	
	4	550	-142.356	-25.9%	
SW G20	Roof	0		0.0%	52.35%
	9	135	-70.6621	-52.3%	
	8	262	-141.2126	-53.9%	
	7	373	-201.2033	-53.9%	
	6	448	-255.4404	-57.0%	
	5	521	-254.5154	-48.9%	
	4	550	-283.3444	-51.5%	
SW G12	Roof	0		0.0%	6.31%
	9	135	0	0.0%	
	8	262	0	0.0%	
	7	373	-25.7254	-6.9%	
	6	448	-16.5461	-3.7%	
	5	521	-43.5346	-8.4%	
	4	550	-43.4387	-7.9%	
SW G17	Roof	0		0.0%	0.79%
	9	135	1.1965	0.9%	
	8	262	-3.1298	-1.2%	
	7	373	-2.5593	-0.7%	
	6	448	-1.2244	-0.3%	
	5	521	-13.0356	-2.5%	
	4	550	-13.0356	-2.4%	
3	569	9.1753	1.6%		

X Direction							
		Floor	Story Shear (k)	Story Force (k)	Overturnir	Percent Stiffness (%)	Relative Stiffness
Frame G0	CMF	Roof	0			0.0%	3.19%
		9	135	-11.6014		8.6%	
		8	262	-8.8243		3.4%	
		7	373	-1.7835		0.5%	
		6	448	-1.7835		0.4%	
		5	521	-36.0712		6.9%	
		4	550	-20.1593		3.7%	
Frame G1	CMF	Roof	0			0.0%	10.71%
		9	135	-61.7276		45.7%	
		8	262	-49.0803		18.7%	
		7	373	-47.7786		12.8%	
		6	448	-45.926		10.3%	
		5	521	-46.5246		8.9%	
		4	550	-36.7834		6.7%	
Frame G2	CMF	Roof	0			0.0%	4.41%
		9	135	-37.7573		18.8%	
		8	262	-25.3608		10.1%	
		7	373	-26.5082		6.4%	
		6	448	-23.855		4.7%	
		5	521	-21.1196		2.8%	
		4	550	-14.5218		2.7%	
Frame G3	SW	Roof	0			0.0%	14.99%
		9	135	-17.1766		12.7%	
		8	262	-32.5672		12.4%	
		7	373	-49.9347		13.4%	
		6	448	-68.1236		15.2%	
		5	521	-57.2748		11.0%	
		4	550	-74.1043		13.5%	
SW G4	SW	Roof	0			0.0%	7.21%
		9	135	1.2711		0.9%	
		8	262	-15.673		6.0%	
		7	373	-27.7274		7.4%	
		6	448	-25.4925		5.7%	
		5	521	-45.6974		8.8%	
		4	550	-45.8749		8.3%	
SW G5	SW	Roof	0			0.0%	19.36%
		9	135	9.3214	121.1782	6.9%	
		8	262	-37.0189	-360.068	14.1%	
		7	373	-66.2374	-1221.15	17.8%	
		6	448	-86.3486	-2343.69	19.3%	
		5	521	-106.9302	-3733.78	20.5%	
		4	550	-122.3003	-5323.68	22.2%	
SW G6	SW	Roof	0			0.0%	38.01%
		9	135	-15.6758		11.6%	
		8	262	-94.0711		35.9%	
		7	373	-153.4909		41.2%	
		6	448	-194.381		44.6%	
		5	521	-199.5865		38.3%	
		4	550	-230.9619		42.0%	
3	569	-198.2092		34.8%			

Appendix G

Typical Plans

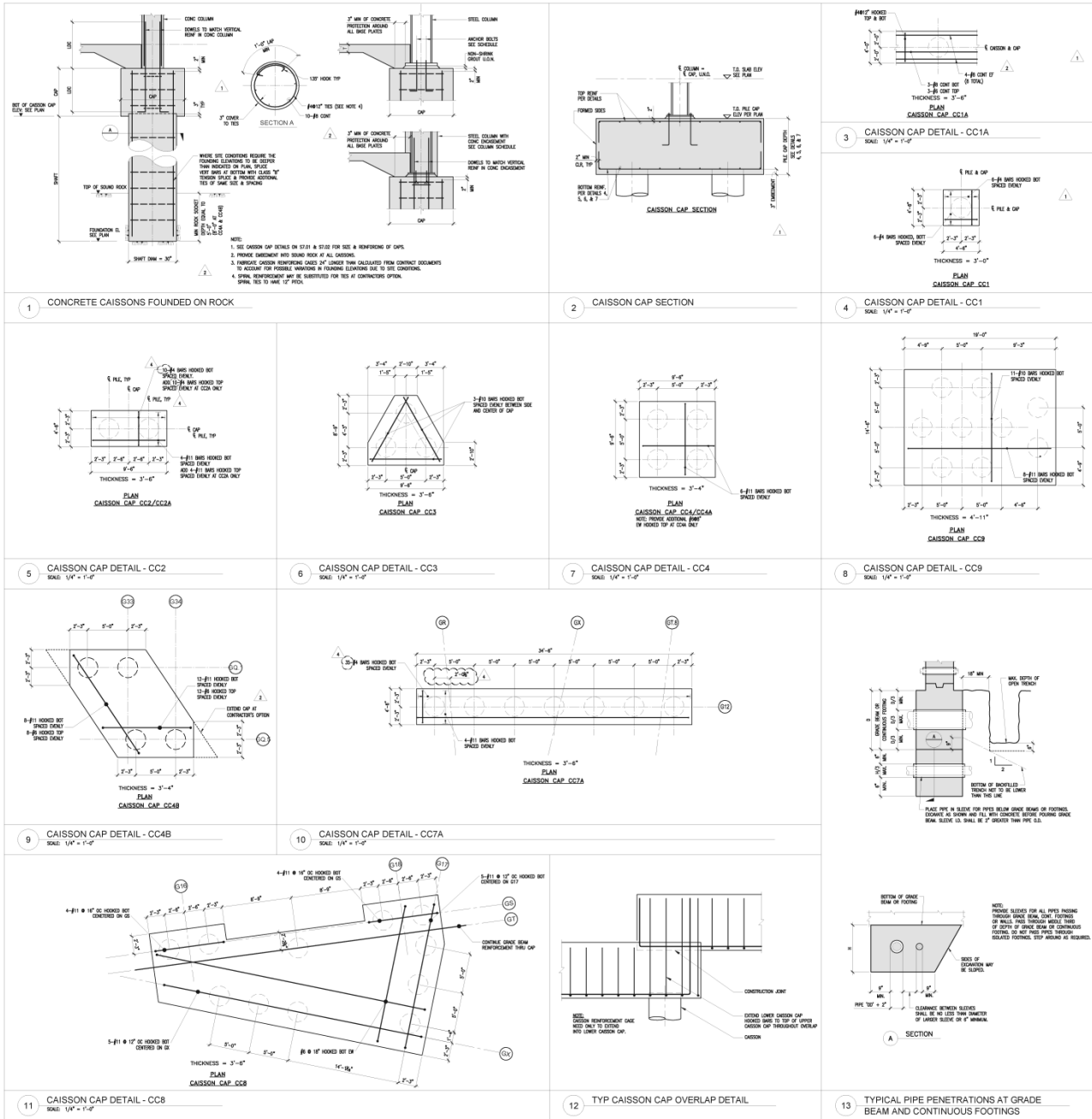

Level 1 Foundation Plan

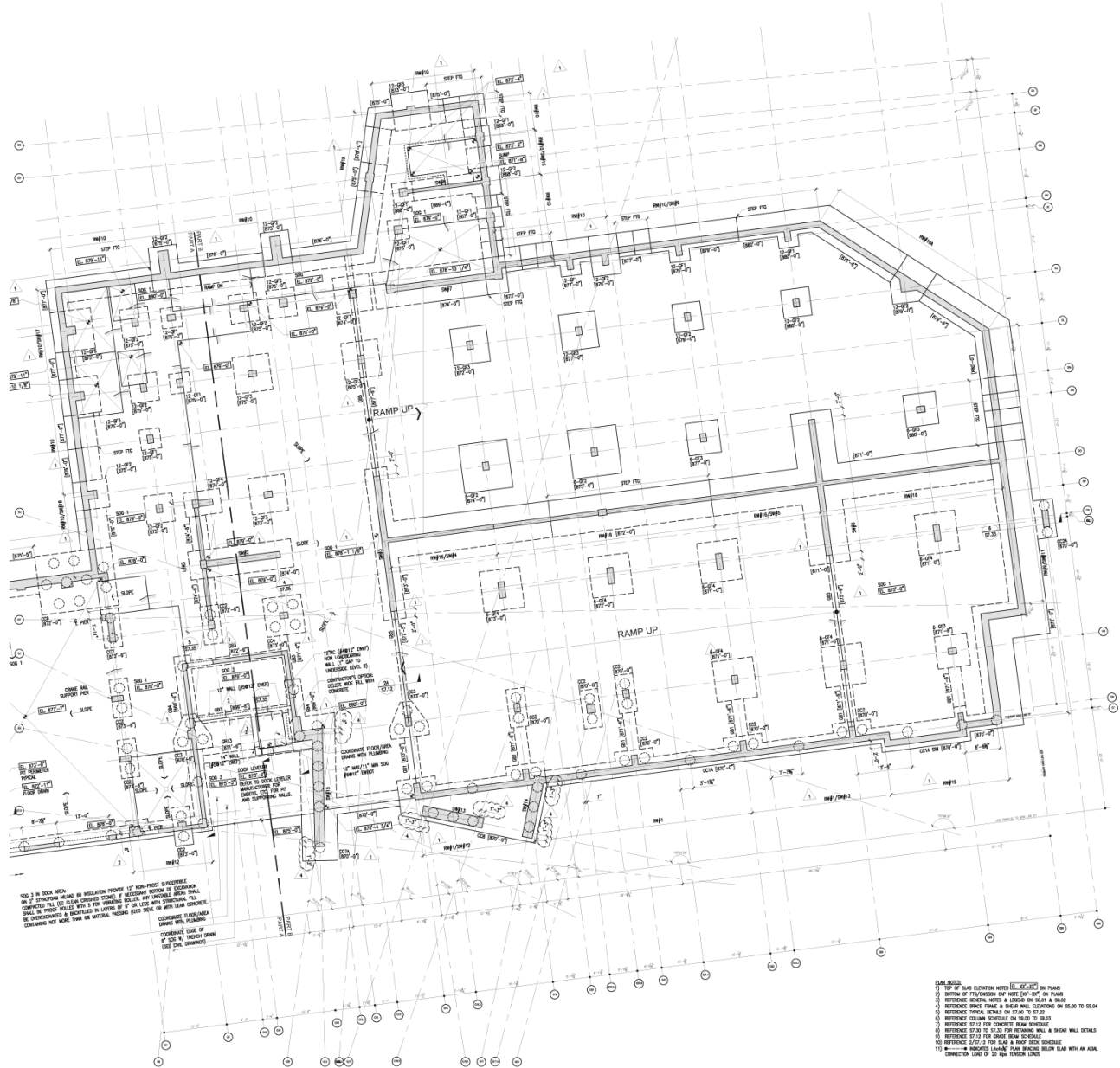

- 1) TOP OF FINISH FLOOR (FF) ON PLANS
 2) BOTTOM OF STRUCTURE DECK (SD) ON PLANS
 3) REFERENCE GRADE (RG) ON PLANS
 4) REFERENCE FINISH FLOOR (FF) ON PLANS
 5) REFERENCE FINISH FLOOR (FF) ON PLANS
 6) REFERENCE FINISH FLOOR (FF) ON PLANS
 7) REFERENCE FINISH FLOOR (FF) ON PLANS
 8) REFERENCE FINISH FLOOR (FF) ON PLANS
 9) REFERENCE FINISH FLOOR (FF) ON PLANS
 10) REFERENCE FINISH FLOOR (FF) ON PLANS
 11) REFERENCE FINISH FLOOR (FF) ON PLANS

Level 3



Level 4



Level 5



Level 6



Level 7

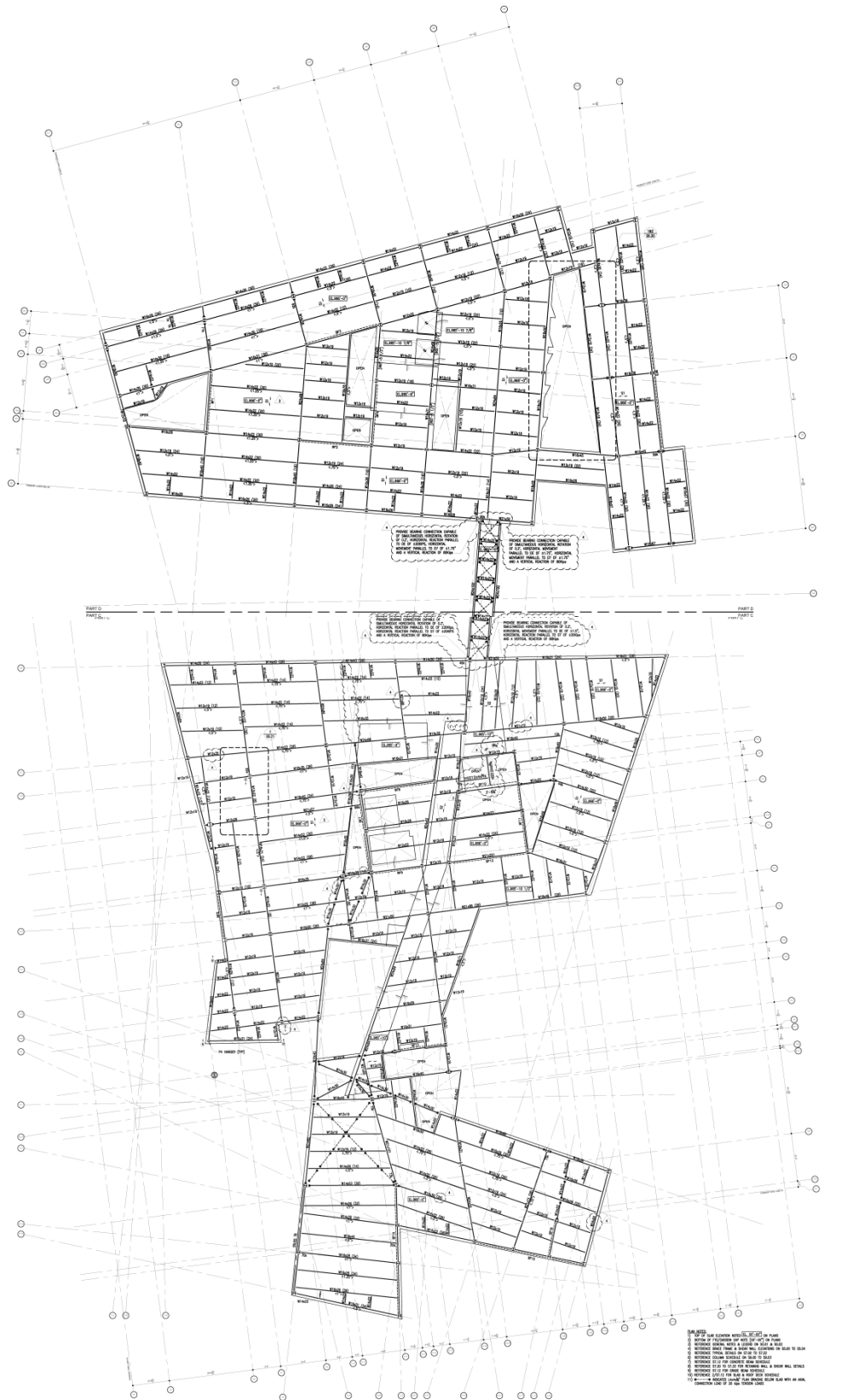

Level 8



